

Steam Trap for Large Condensate
Flowrates

TK 23

TK 24

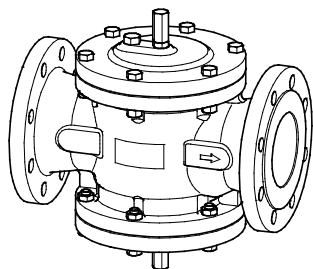

Contents

Foreword	3
Availability.....	3
Formatting features in the document	3
Safety	3
Use for the intended purpose	3
Basic safety notes	4
Information on property damage or malfunctions	4
Qualification of personnel.....	4
Protective gear	5
Typographic features of warning notes.....	5
Formatting features for warnings of property damage	5
Description	5
Scope of supply and equipment specification	5
Task and function.....	9
Storing and transporting the equipment	11
Storing the equipment	11
Transporting the equipment	11
Mounting and connecting the equipment	11
Preparing installation	11
Connecting the equipment	12
Adapting settings	13
Special adjustments for equipment with DN 50	14
Special adjustments for equipment with DN 65	24
Operation	34
After operation	34
Removing external dirt deposits.....	34
Maintaining the equipment.....	34
Servicing the equipment and installing spare parts	42
Troubleshooting	49
Putting the equipment out of operation	52
Removing harmful substances.....	52
Removing the equipment	52
Re-using equipment after storage.....	53
Disposing of the equipment.....	53
Technical data	54
Dimensions and weights	54
Pressure & temperature ratings.....	55
Capacity Charts	56
Lift-Restriction Charts	58
Manufacturer's declaration	61

Foreword

This installation & operating manual will help you use the following types of equipment safely and efficiently for their intended purpose.

- ▶ TK 23
- ▶ TK 24

These steam traps will be called equipment in this document.

This installation & operating manual is intended for anyone commissioning, using, operating, servicing, cleaning or disposing of this equipment and, in particular, for professional after-sales service technicians, qualified personnel and authorised and trained staff.

All of these persons must read and understand the content of this installation & operating manual.

Following the instructions given in this installation & operating manual helps avoiding danger and increases the reliability and service life of the equipment. Please note that in addition to the instructions given in this installation & operating manual you must also observe all locally applicable rules and regulations concerning the prevention of accidents as well as approved safety guidelines for good professional practice.

Availability

Keep this installation & operating manual together with the plant documentation for future reference. Make sure that this installation & operating manual is available to the operator.

The installation & operating manual is part of the equipment. Please hand over this installation & operating manual when selling the equipment or passing it on.

Formatting features in the document

Certain text elements of this installation & operating manual feature a specific typographic design. You can easily distinguish the following text elements:

Standard text

Cross-reference

- ▶ Listing
 - ▶ Sub-items in listings
- Steps for action.



Here you will find additional useful information and tips serving to assist you in using the equipment to its fullest potential.

Safety

Use for the intended purpose

The following thermostatic/thermodynamic steam traps are installed in steam lines:

- ▶ TK 23
- ▶ TK 24

The equipment is designed for discharging large condensate flowrates that are produced continuously and for air-venting pipelines.

The equipment must only be used within the allowable pressure and temperature limits and only if the chemical and corrosive influences on the equipment are taken into account.

Do not expose the control membrane of the membrane regulator capsule to superheat conditions above 5 °C.

Correct use includes compliance with the instructions given in this installation & operating manual, in particular obedience to all safety instructions.

Any other use of the equipment is considered to be improper.

Note that the equipment is also used incorrectly if the materials of the equipment are not suitable for the fluid.

Basic safety notes

Risk of severe injuries

- ▶ The equipment is under pressure during operation and may be hot. Before carrying out any work on the equipment make sure that the following requirements are met:
 - ▶ The pipes must be depressurized (0 bar).
 - ▶ The fluid must be completely removed from the pipes and the equipment.
 - ▶ During work on the equipment the installation must be switched off and protected against unauthorised or unintended activation.
 - ▶ The pipes and the equipment must have cooled down to room temperature (approx. 20 °C).
- ▶ If the equipment is used in contaminated areas there is a risk of severe injuries or death caused by harmful substances in or on the equipment. Before working on the equipment make sure that it is completely decontaminated. Always wear the protective clothing prescribed for contaminated areas when working on the equipment.
- ▶ The equipment must only be used with fluids that do not attack the material and the gaskets and sealings of the equipment. Otherwise leaks may occur and hot or toxic fluid could escape.
- ▶ The equipment and its component parts must only be mounted or removed by qualified personnel. A qualified person must be acquainted with and experienced in the following:
 - ▶ Making pipe connections.
 - ▶ Selecting suitable lifting gear and understanding the rules for its safe use.
 - ▶ Working with dangerous (contaminated, hot or pressurized) fluids.

Risk of minor injuries

- ▶ Sharp edges on internals present the danger of cuts to hands. Always wear industrial gloves when servicing the equipment.
- ▶ If the support of the equipment during installation is insufficient the equipment might fall down, thereby causing bruises or injuries. Make sure the equipment is safely held in place during installation and cannot fall down. Wear protective safety footwear.

Information on property damage or malfunctions

- ▶ Malfunctions will occur if the equipment is installed in a wrong position or with the flow arrow pointing in the opposite direction of the fluid flow. This may result in damage to the equipment or the installation. Make sure that the flow arrow on the equipment body matches the indicated direction of the fluid flow in the pipe.
- ▶ If the material is unsuitable for the fluid, increased wear may occur and fluid may escape. Make sure that the material is suitable for the fluid used in your installation.

Qualification of personnel

A qualified person must be acquainted with and experienced in the following:

- ▶ the pertinent on-site rules and regulations for preventing fire and explosions as well as industrial safety regulations
- ▶ working on pressure equipment
- ▶ making pipe connections
- ▶ working with dangerous (hot or pressurized) fluids
- ▶ lifting and transporting loads
- ▶ observing all notes and instructions in this installation & operating manual and the applicable documents

Protective gear

The required protective gear depends on the types of fluid used and the regulations on site. For more information on suitable safety clothing and safety gear refer to the safety data sheet of the fluid in question.

Protective gear comprises the following items:

- ▶ protective helmet
- ▶ work boots
- ▶ industrial leather gloves

Typographic features of warning notes



DANGER

Notes with the heading DANGER warn against imminent dangerous situations that can lead to death or serious injuries.



WARNING

Notes with the heading WARNING warn against possibly dangerous situations that could lead to death or serious injuries.



CAUTION

Notes with the heading CAUTION warn against dangerous situations that could lead to minor or moderate injuries.

Formatting features for warnings of property damage

Attention!

This information warns of a situation leading to property damage.

Description

Scope of supply and equipment specification

Scope of supply

Our equipment is delivered packed and ready for assembly.

Equipment specification

TK 23 and TK 24 are operationally identical but differ in their limiting conditions and materials of construction.

Equipment of type TK 23 is rated for nominal pressure PN16, TK 24 for nominal pressure PN 25.

Equipment of various sizes differ in the following

- ▶ Equipment with DN 50 is provided with one adjustment screw in the cover. The adjustment screw can be used to set either a minimum flowrate or a maximum flowrate. This equipment type features three membrane regulator capsules.
- ▶ Equipment from DN 65 onwards has two covers, each one provided with one adjustment screw. With the adjustment screw in the top cover you can set the maximum flowrate. With the adjustment screw in the bottom cover you can set the minimum flowrate. This equipment type features four membrane regulator capsules.

The following membrane regulator capsules are available:

- ▶ Type 5H2 (standard)
- ▶ Type 0H2 (for differential pressures below 1 bar and operating pressures up to 5 bar)

Explosion view of equipment DN 50

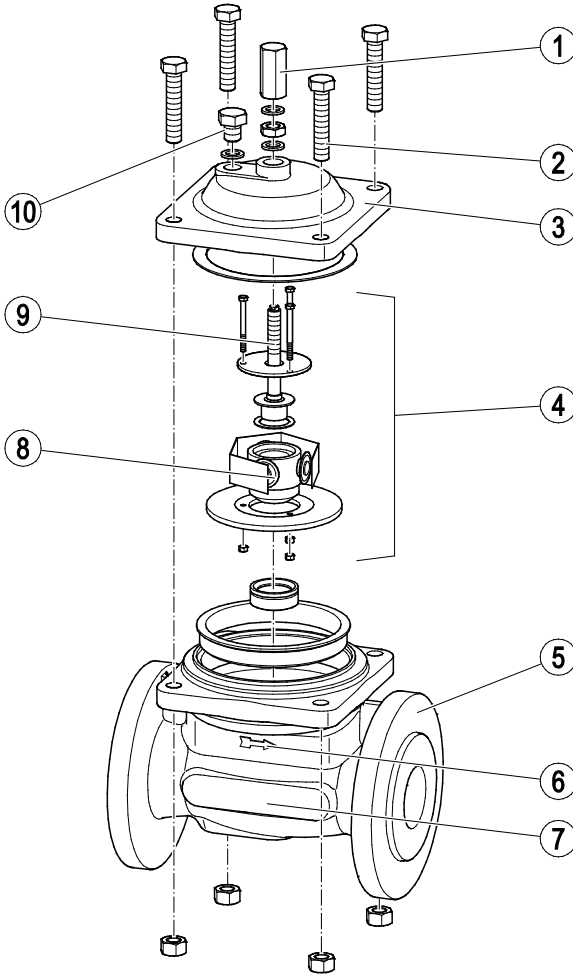

Item no.	Designation
1	Cap nut
2	Hexagon-head cap bolts (4 pcs.)
3	Cover
4	Regulator unit
5	Body

Item no.	Designation
6	Direction of flow arrow
7	Type specification on body (instead of name plate)
8	Thermostatic (membrane regulator) capsule (3 pcs.)
9	Adjustment screw
10	Sealing plug

Explosion view of equipment DN 65 - 100

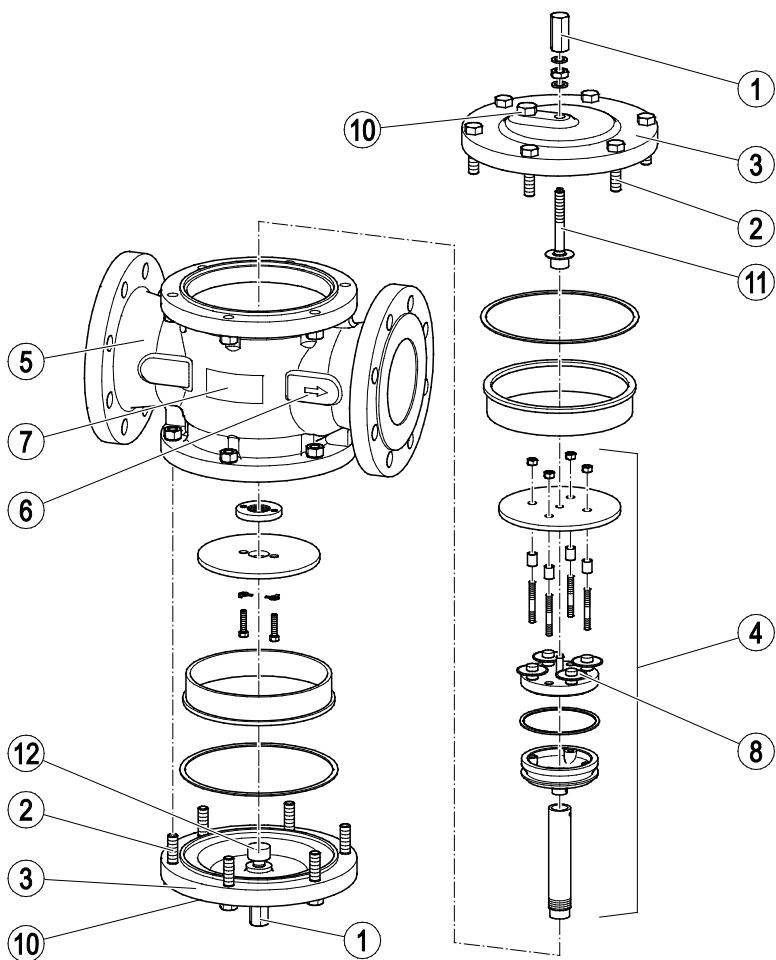

Item no.	Designation
1	Cap nut (2 pcs.)
2	Hexagon-head cap bolts (6 pcs. per cover)
3	Cover (2 pcs.)
4	Regulator unit
5	Body
6	Direction of flow arrow

Item no.	Designation
7	Type specification on body (instead of name plate)
8	Thermostatic (membrane regulator) capsule (4 pcs.)
10	Sealing plug (2 pcs.)
11	Adjustment screw for maximum flowrate
12	Adjustment screw for minimum flowrate (leak passage)

Markings on the membrane regulator capsule

The following membrane regulator capsules are available:

- ▶ Type 5H2 (standard)
- ▶ Type 0H2 (for differential pressures below 1 bar and operating pressures up to 5 bar)

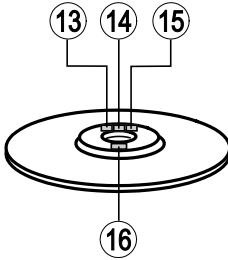

Item no.	Description
13	Code number for type
14	Code letter for opening temperature
15	Code number for capacity
16	Manufacturing code

End connections

The equipment is available with the following end connections:

- ▶ Flanges

Name plate

Instead of a nameplate the following items are specified directly on the body:

- ▶ Manufacturer
- ▶ Type designation
- ▶ Nominal size
- ▶ Pressure rating
- ▶ Material
- ▶ CE marking
- ▶ Direction of flow
- ▶ Manufacturing date (quarter/year)

Application of European Directives

Pressure Equipment Directive

The equipment conforms to this directive (see "Manufacturer's Declaration" section) and can be used for the following media:

- ▶ Fluids of group 2

ATEX Directive

The equipment does not have its own potential ignition source and is not subject to this directive (see "Manufacturer's Declaration" section).

When installed, static electricity may arise between the equipment and the connected system. When used in potentially explosive atmospheres, the plant manufacturer or plant operator is responsible for discharging or preventing possible static charge.

If it is possible for medium to escape, e.g. through actuating mechanisms or leaks in threaded joints, the plant manufacturer or plant operator must take this into consideration when dividing the area into zones.

Task and function

Purpose

The equipment is designed for discharging large condensate flowrates that are produced continuously and for air-venting pipelines.

The equipment opens and closes as a function of the membrane regulator (thermostatic capsules) immediately below the pressure-dependent saturation temperature.

At start-up and during operation the equipment automatically vents non-condensable gases.

Function (equipment with DN 50)

The membrane regulator capsules and the upstream pressure of the condensate control the discharge of condensate.

If undercooled or cold condensate, or air or other incondensable gases are present, the membrane regulator capsules are in the open position.

The pressure in the chamber (18) drops below the upstream pressure and, as a consequence, the regulator unit is lifted and the valve (20) opens. The condensate or the gas is discharged.

A small part of the fluid ("leak passage") flows through the regulator unit with the membrane regulator capsules. This partial flow enters the chamber through the annular slot (17) and flows through the regulator unit and the cone (19) before it is discharged.

This ensures that the membrane regulator capsules always have the same temperature as the fluid.

Immediately before the boiling temperature of water is reached the membrane regulator capsules are back in the closed position.

The partial flow can no longer drain. Inside the chamber pressure builds up until it reaches the upstream pressure of the fluid and the valve is closed.

The lift plate (21) prevents the steam trap from opening and closing abruptly.

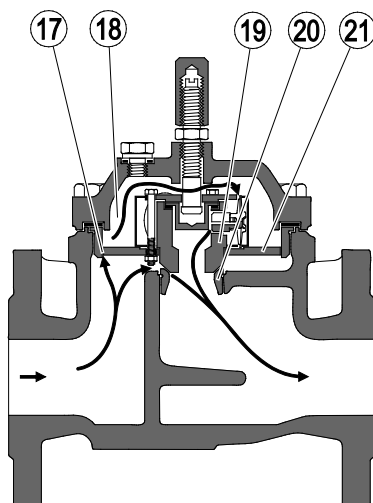

Function (equipment with DN 65 - 100))

The membrane regulator capsules and the upstream pressure of the condensate control the discharge of condensate.

If undercooled or cold condensate, or air or other incondensable gases are present, the membrane regulator capsules are in the open position.

The pressure in the chamber (18) increases until it reaches upstream pressure. As a result the regulator unit is lifted, the valve (20) opens and the condensate or gas drains.

A small part of the fluid ("leak passage") flows through the regulator unit with the membrane regulator capsules. This partial flow enters the valve body and the tube (24), flows into the chamber and leaves through the annular slot (17) and the cone (19).

This ensures that the membrane regulator capsules always have the same temperature as the fluid.

Immediately before the boiling temperature of water is reached the membrane regulator capsules are back in the closed position.

The annular slot causes the pressure in the chamber to drop and, consequently, the valve closes.

The dampening plate (22) and the chamber (23) prevent the steam trap from opening and closing abruptly.

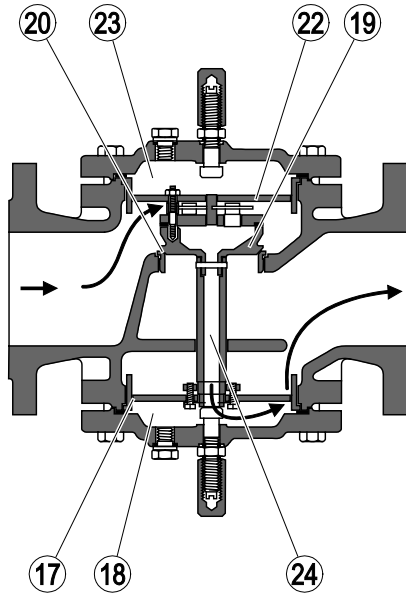

Manual setting

In addition to the automatic opening and closing process you can also adjust the valve opening manually.

Equipment with DN 50 has only one adjustment screw. With this equipment you can only adjust either a maximum or a minimum flowrate. Equipment from DN 65 onwards is provided with two adjustment screws. Use the adjustment screw on the top cover to regulate the maximum flowrate. Use the adjustment screw on the bottom cover to regulate the minimum flowrate.

Storing and transporting the equipment

Attention!

Equipment can be damaged if stored or transported improperly.

- Close all openings with the sealing plugs or covers supplied with the equipment or use similar sealing covers.
- Protect the equipment against moisture and corrosive atmospheres.
- Please contact the manufacturer if the specified transport and/or storage requirements cannot be met.

Storing the equipment

- Please observe the following items when storing the equipment:
 - ▶ Do not store the equipment for more than 12 months.
 - ▶ Use the supplied sealing plugs or other suitable seal caps in order to seal off all openings of the equipment.
 - ▶ Protect the sealing surfaces and contact areas against mechanical damage.
 - ▶ Protect the equipment and all components against hard shocks and impacts.
 - ▶ Store the equipment only in closed rooms that meet the following environmental conditions:
 - ▶ Air humidity below 50 %, not condensing
 - ▶ Indoor air: clean, salt-free and non-corrosive
 - ▶ Temperature 5–40 °C.
- Make sure that all these requirements are always met when storing the equipment.
- Please contact the manufacturer if you cannot comply with the recommended storage conditions.

Transporting the equipment

- Meet the requirements for storage also when transporting the equipment.
- Prior to transport seal off connections with sealing plugs.



If you do not have the sealing plugs supplied with the equipment use appropriate seal caps to seal off the connections.

- For short distances (only a few metres) you can transport the equipment unpacked.
- When transporting the equipment over larger distances use the original packaging.
- If you do not have the original packaging use a box that protects the equipment adequately against corrosion and physical damage.



For a short period of time the equipment may be transported even if the temperature is below 0 °C, provided that the equipment is completely empty and dry.

Mounting and connecting the equipment

Preparing installation

- Take the equipment out of the transport packaging.
- Check the equipment for transport damage.
- Contact the manufacturer if you detect any kind of shipping damage.

When supplied by the factory, the connections may be sealed off with sealing plugs.

- Remove sealing plugs before mounting the equipment.
- Keep the sealing plugs and the packing for further use.



DANGER

Personnel working on pipes are exposed to safety risks and may suffer severe injuries, poisoning or even loss of life.

- Make sure that no hot or hazardous fluid is in the equipment or the pipes.
- Make sure that the pipes upstream and downstream of the equipment are depressurised.
- Make sure that the installation is switched off and protected against unauthorised or unintended activation.
- Make sure that the equipment and the pipes have cooled down to room temperatures.
- Wear protective clothing that is suitable for the fluid and, if necessary, wear protective gear.

For more information on suitable protective clothing and safety gear refer to the safety data sheet of the fluid in question.

- Drain pipes until they are empty.
- Switch the installation off and protect it against unauthorised or unintended re-activation.

Connecting the equipment



DANGER

Incorrectly connected equipment can cause fatal accidents or severe injuries.

- Make sure that only qualified skilled personnel connect the equipment to pipes.
- Make sure that the flow arrow on the equipment body matches the direction of flow in the pipe.

Specialist personnel must be highly qualified and fully experienced in making pipe connections for the respective type of end connection.

Attention!

Equipment will be damaged if the end connections are undersized.

- Make sure that the connections are strong and rigid enough to support the weight of the equipment and to withstand the forces that occur during operation.

To allow easy access for routine servicing and exchanging components observe the indicated withdrawal distances and allow for clearances to adjacent installation parts.

For more information see chapter "*Dimensions and weights*" on page 54.

- Make sure that the pipe system of the plant is clean.

The equipment can be installed in any position.

For best protection against dirt install the equipment preferably with the valve pointing upwards.

- Make sure that the equipment is free from foreign matter.
- Mount the equipment in the desired installation position.
- Make sure that the equipment is safely mounted and that all connections are made correctly.

Attention!

Malfunctions may occur if the equipment or condensate line is insulated.

- Make sure that the heat generated by the equipment or the condensate line is dissipated.
-

Adapting settings

To guarantee a rapid response to temperature changes, the membrane regulator capsules are permanently exposed to defined partial flow of the fluid (= minimum flowrate, so-called "leak passage").

The following default partial flow settings are adjusted at our factory:

- ▶ Equipment with DN 50: 2 % of the maximum flowrate
- ▶ Equipment with DN 65 - 80: 1.5% of the maximum flowrate
- ▶ Equipment with DN 100: 1% of the maximum flowrate

With factory setting the equipment discharges the quantities given in the capacity charts on page 56.

To custom fit the steam trap to the individual operating conditions of your installation you can adjust the flowrate by limiting the valve travel ("lift restriction") for the open or closed position.

Equipment with DN 50 is provided with only one adjustment screw. With this equipment you can only adjust either a maximum or a minimum flowrate ("leak passage").

Equipment from DN 65 onwards is provided with two adjustment screws. Use the adjustment screw on the top cover to regulate the maximum flowrate. Use the adjustment screw on the bottom cover to regulate the minimum flowrate.



DANGER

Personnel working on pipes are exposed to safety risks and may suffer severe injuries, poisoning or even loss of life.

- Make sure that no hot or hazardous fluid is in the equipment or the pipes.
- Make sure that the pipes upstream and downstream of the equipment are depressurised.
- Make sure that the installation is switched off and protected against unauthorised or unintended activation.
- Make sure that the equipment and the pipes have cooled down to room temperatures.
- Wear protective clothing that is suitable for the fluid and, if necessary, wear protective gear.

For more information on suitable protective clothing and safety gear refer to the safety data sheet of the fluid in question.

For work on the equipment you will need the following tools:

- ▶ Torque spanner (US: wrench) 4-40 Nm
- ▶ Torque spanner (US: wrench) 20-120 Nm
- ▶ 2 Spanners A. F. 8 mm
- ▶ 2 Spanners A. F. 19 mm (TK 23) or 24 mm (TK 24)
- ▶ Screwdriver 6 mm
- ▶ Screwdriver 10 mm

Attention!

Equipment may leak if the gasket is damaged.

- Replace all gaskets that you loosen during your work.
- Use only new gaskets of the same type.

When working on the equipment you have to loosen several screws. Loosening a screw may impair the associated gasket. Therefore always replace the gasket with a new one of the same type.

For more information on the required gasket types refer to section "*Servicing the equipment and installing spare parts*" from page 42 onwards.

Special adjustments for equipment with DN 50

Equipment with DN 50 has only one adjustment screw. With this equipment you can only adjust either a maximum or a minimum flowrate ("leak passage").

If the minimum flowrate is set to zero the equipment gives steam-tight shut-off.

Limiting the maximum flowrate

To ensure that the equipment discharges condensate as continuously as possible you have to reduce the maximum flowrate.

To do so you must limit the valve travel in the opening direction.

Attention!

Malfunctions due to banking-up of condensate.

Limiting the maximum flowrate changes the factory-set leak passage ("partial flow"). The equipment closes as soon as steam arrives. Note that the responsiveness of the membrane regulator is reduced due to the lack of a partial flow. As a result condensate may bank up.

- Make sure that the process in the higher-level plant system is not impaired by banking-up of condensate.

To ascertain the required number of turns of the adjustment screw proceed as follows:

- Determine the ratio of the desired maximum flowrate to the flowrate set at our factory.
- Refer to the lift restriction chart to ascertain the number of turns of the adjustment screw that corresponds to this ratio.

The capacity charts are shown in section "*Capacity Charts*" on page 56.

The lift restriction charts are shown in section "*Lift-Restriction Charts*" from page 58 onwards.

Example

The charts shown in this example are reduced in size. Use the charts in original size to ascertain the required setting.

A max. flowrate of 6.75 t/h for hot fluid and a differential pressure of 0.85 bar is desired.

Using the capacity chart for hot fluid you can determine that for a differential pressure of 0.85 bar the factory-set flowrate is 9 t/h.

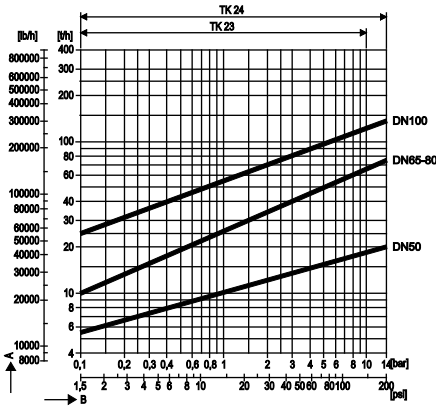

This yields a ratio of $(6.75 \times 100)/9 = 75\%$.

According to the lift-restriction chart a ratio of 75 % (line "A") corresponds to one turn to the right of the adjustment screw.

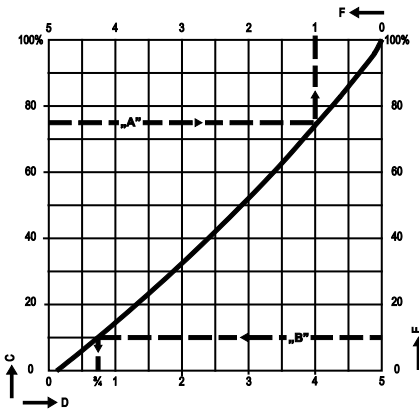

- Make sure that the equipment is depressurized, cooled down to room temperature and free from fluid.
- To reduce the pressure through the bore in the cover slowly loosen the sealing plug by two turns (10).
- Remove the cap nut (1).
- Remove the outer gasket (26) from the adjustment screw.
- Remove the hexagon nut (25).
- Remove the inner gasket (26) from the adjustment screw.
- Screw in the adjustment screw (9) until it hits the stop.

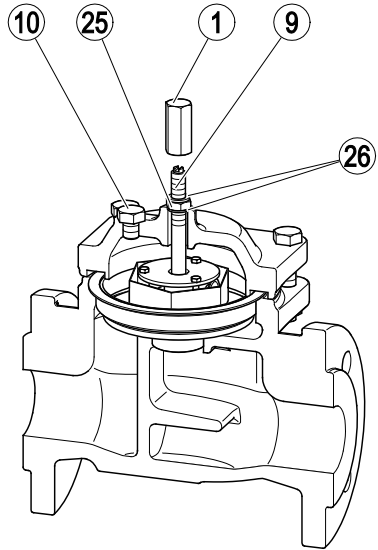

- Remove the sealing plug (10).
- Take the gasket (27) out of the body.
- Insert a screwdriver through the bore for the sealing plug and push down the lift plate (21).
- Loosen the adjustment screw (9) until the lift plate starts to lift.
- To reduce the maximum flowrate tighten the adjustment screw by the number of turns specified in the chart.

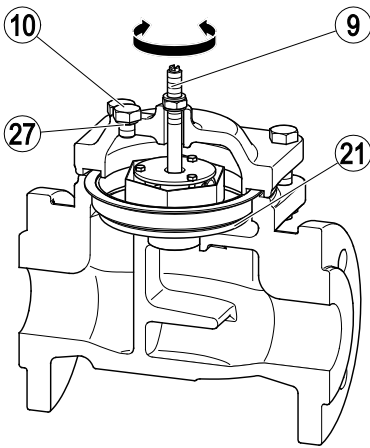

Attention!

Equipment may leak if the gasket is damaged.

- Replace all gaskets that you loosen during your work.
 - Use only new gaskets of the same type.
-
- Put the new inner gasket (26) onto the adjustment screw.
 - Put the hexagon nut (25) onto the adjustment screw (9).
 - Make sure that the adjustment screw cannot rotate.

For this purpose you can for example push the tip of a screwdriver into the slot of the adjustment screw.

- Tighten the hexagon nut (25) with a torque of 30 Nm.
- Put the new outer gasket (26) onto the adjustment screw.
- Screw the cap nut (1) onto the adjustment screw.
- Tighten the cap nut with a torque of 30 Nm.
- Insert the new gasket (27) into the bore of the sealing plug.
- Put the sealing plug (10) into the bore.

The torque for the sealing plug depends on the equipment type.

- Equipment of type TK 23 requires a torque of 30 Nm.
 - Equipment of type TK 24 requires a torque of 40 Nm.
- Fasten the sealing plug with the specified torque.

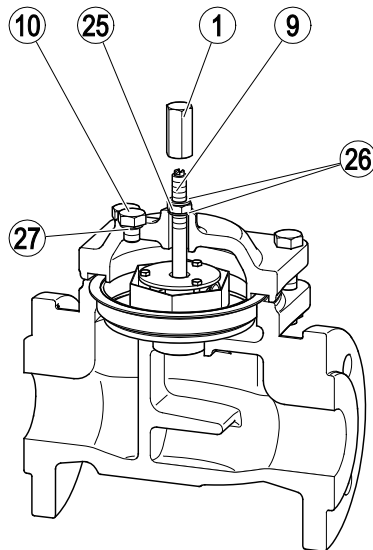

Adjusting a minimum flowrate

To adjust a minimum flowrate (partial flow, "leak passage") change the valve travel in the closing direction.

Before changing the settings determine the required turns as follows:

To ascertain the required number of turns of the adjustment screw proceed as follows:

- Determine the ratio of the desired minimum flowrate to the flowrate set at our factory.
- Refer to the lift restriction chart to ascertain the number of turns of the adjustment screw that corresponds to this ratio.

The capacity charts are shown in section "Capacity Charts" on page 56.

The lift restriction charts are shown in section "Lift-Restriction Charts" from page 58 onwards.

Example

The charts shown in this example are reduced in size. Use the charts in original size to ascertain the required setting.

A minimum flowrate of 0.9 t/h for hot fluid and a differential pressure of 0.85 bar is desired.

Using the capacity chart for hot fluid you can determine that for a differential pressure of 0.85 bar the factory-set flowrate is 9 t/h.

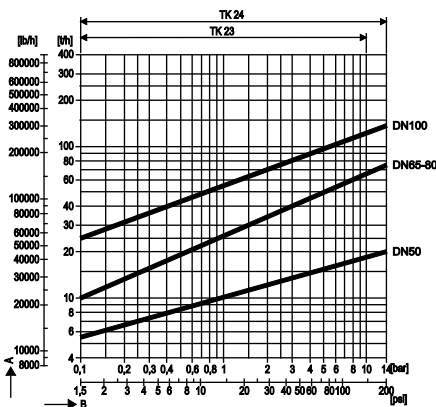

This yields a ratio of $(0.9 \times 100)/9 = 10\%$.

According to the lift-restriction chart a ratio of 10% (line "B") corresponds to $\frac{3}{4}$ turn to the left of the adjustment screw.

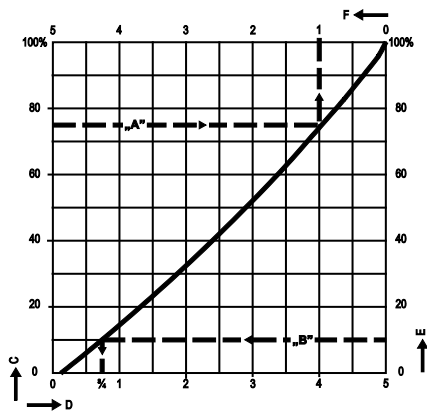

- Make sure that the equipment is depressurized, cooled down to room temperature and free from fluid.
- To reduce the pressure through the bore in the cover slowly loosen the sealing plug by two turns (10).
- Remove the cap nut (1).
- Remove the outer gasket (26) from the adjustment screw.
- Remove the hexagon nut (25).
- Remove the inner gasket (26) from the adjustment screw.
- Screw in the adjustment screw (9) until it hits the stop.

- To change the minimum flowrate loosen the adjustment screw by the number of turns specified in the chart.

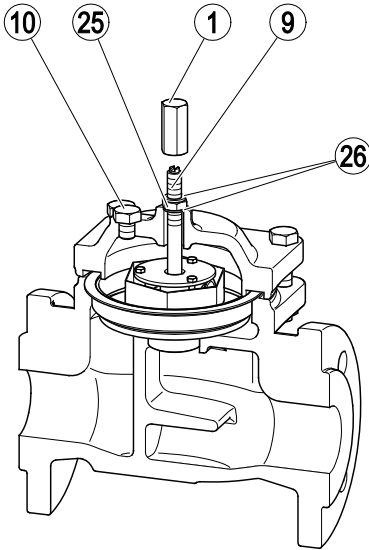
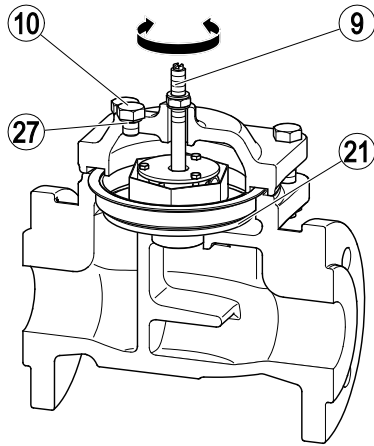

- Remove the sealing plug (10).
- Take the gasket (27) out of the body.
- Insert a screwdriver through the bore for the sealing plug and push down the lift plate (21).
- Loosen the adjustment screw (9) until the lift plate starts to lift.

Attention!

Equipment may leak if the gasket is damaged.

- Replace all gaskets that you loosen during your work.
- Use only new gaskets of the same type.

-
- Put the new inner gasket (26) onto the adjustment screw.
 - Put the hexagon nut (25) onto the adjustment screw (9).
 - Make sure that the adjustment screw cannot rotate.

For this purpose you can for example push the tip of a screwdriver into the slot of the adjustment screw.

- Tighten the hexagon nut (25) with a torque of 30 Nm.
- Put the new outer gasket (26) onto the adjustment screw.
- Screw the cap nut (1) onto the adjustment screw.
- Tighten the cap nut with a torque of 30 Nm.
- Insert the new gasket (27) into the bore of the sealing plug.
- Put the sealing plug (10) into the bore.

The torque for the sealing plug depends on the equipment type.

- Equipment of type TK 23 requires a torque of 30 Nm.
 - Equipment of type TK 24 requires a torque of 40 Nm.
- Fasten the sealing plug with the specified torque.

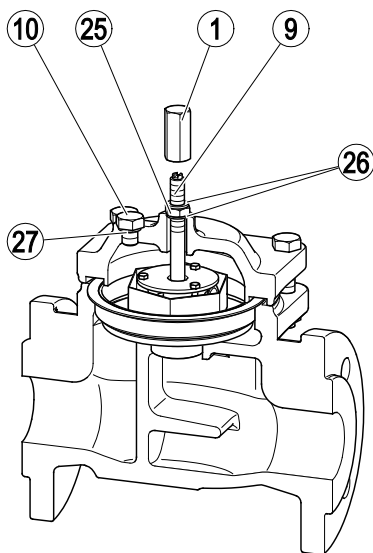

Adjustment to give steam-tight shut-off

To prevent steam loss you can adjust the equipment to give steam-tight shut-off. To do so you have to set the minimum flowrate to zero.

Attention!

Malfunctions due to banking-up of condensate.

Limiting the maximum flowrate changes the factory-set leak passage ("partial flow"). The equipment closes as soon as steam arrives. Note that the responsiveness of the membrane regulator is reduced due to the lack of a partial flow. As a result condensate may bank up.

- Make sure that the process in the higher-level plant system is not impaired by banking-up of condensate.
-
- Make sure that the equipment is depressurized, cooled down to room temperature and free from fluid.
 - To reduce the pressure through the bore in the cover slowly loosen the sealing plug by two turns (10).
 - Remove the cap nut (1).
 - Remove the outer gasket (26) from the adjustment screw.
 - Remove the hexagon nut (25).
 - Remove the inner gasket (26) from the adjustment screw.
 - Screw in the adjustment screw (9) until it hits the stop.

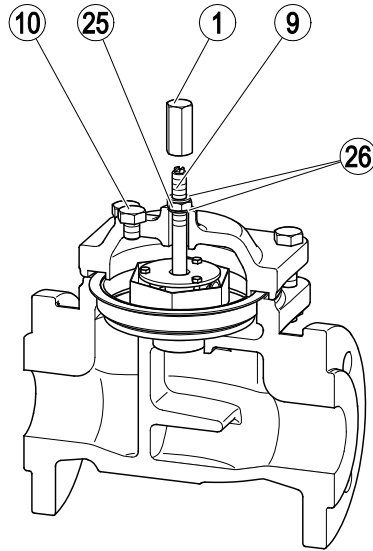

- Remove the sealing plug (10).
- Take the gasket (27) out of the body.
- Insert a screwdriver through the bore for the sealing plug and push down the lift plate (21).
- Loosen the adjustment screw (9) until the lift plate starts to lift.
- Tighten the adjustment screw a quarter turn.

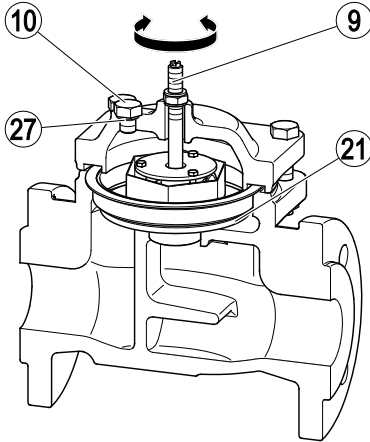

- Tighten the hexagon nut (25) with a torque of 30 Nm.
- Put the new outer gasket (26) onto the adjustment screw.
- Screw the cap nut (1) onto the adjustment screw.
- Tighten the cap nut with a torque of 30 Nm.
- Insert the new gasket (27) into the bore of the sealing plug.
- Put the sealing plug (10) into the bore.

The torque for the sealing plug depends on the equipment type.

- ▶ Equipment of type TK 23 requires a torque of 30 Nm.
- ▶ Equipment of type TK 24 requires a torque of 40 Nm.
- Fasten the sealing plug with the specified torque.

Attention!

Equipment may leak if the gasket is damaged.

- Replace all gaskets that you loosen during your work.
- Use only new gaskets of the same type.

- Put the new inner gasket (26) onto the adjustment screw.
- Put the hexagon nut (25) onto the adjustment screw (9).
- Make sure that the adjustment screw cannot rotate.

For this purpose you can for example push the tip of a screwdriver into the slot of the adjustment screw.

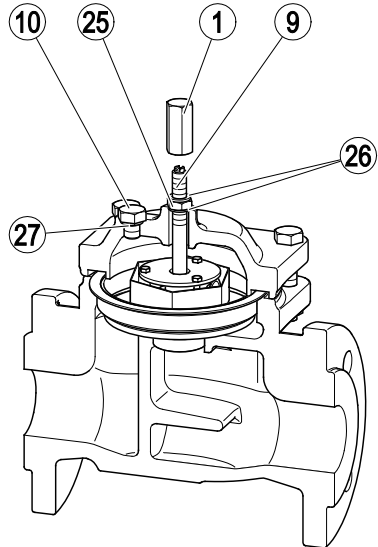

Restoring default factory settings

To re-adjust the factory settings of the flowrates proceed as follows:

- Make sure that the equipment is depressurized, cooled down to room temperature and free from fluid.
- To reduce the pressure through the bore in the cover slowly loosen the sealing plug by two turns (10).
- Remove the cap nut (1).
- Remove the outer gasket (26) from the adjustment screw.
- Remove the hexagon nut (25).
- Remove the inner gasket (26) from the adjustment screw.
- Screw in the adjustment screw (9) until it hits the stop.

- Loosen the adjustment screw a quarter turn.

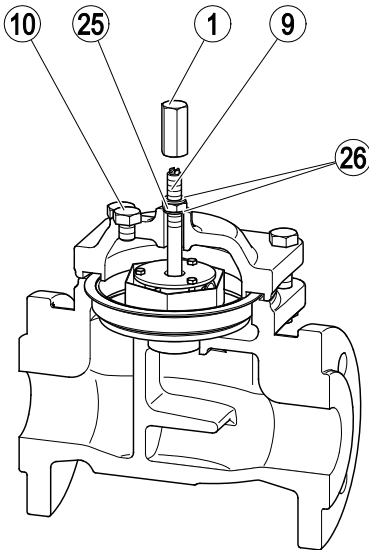
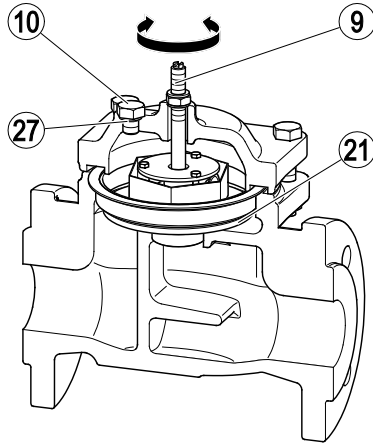

- Remove the sealing plug (10).
- Take the gasket (27) out of the body.
- Insert a screwdriver through the bore for the sealing plug and push down the lift plate (21).
- Loosen the adjustment screw (9) until the lift plate starts to lift.

Attention!

Equipment may leak if the gasket is damaged.

- Replace all gaskets that you loosen during your work.
- Use only new gaskets of the same type.

-
- Put the new inner gasket (26) onto the adjustment screw.
 - Put the hexagon nut (25) onto the adjustment screw (9).
 - Make sure that the adjustment screw cannot rotate.

For this purpose you can for example push the tip of a screwdriver into the slot of the adjustment screw.

- Tighten the hexagon nut (25) with a torque of 30 Nm.
- Put the new outer gasket (26) onto the adjustment screw.
- Screw the cap nut (1) onto the adjustment screw.
- Tighten the cap nut with a torque of 30 Nm.
- Insert the new gasket (27) into the bore of the sealing plug.
- Put the sealing plug (10) into the bore.

The torque for the sealing plug depends on the equipment type.

- Equipment of type TK 23 requires a torque of 30 Nm.
 - Equipment of type TK 24 requires a torque of 40 Nm.
- Fasten the sealing plug with the specified torque.

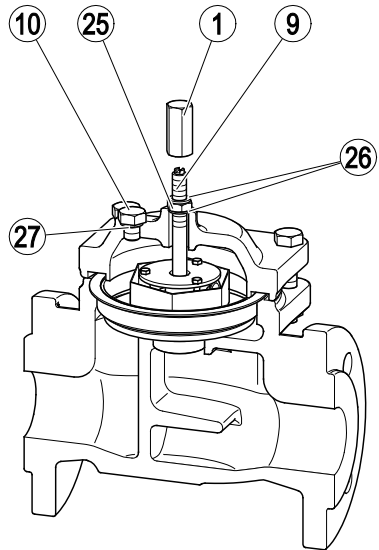

Special adjustments for equipment with DN 65

Equipment from DN 65 onwards is provided with two adjustment screws. With this equipment you can adjust a maximum and a minimum flowrate (= partial flow, "leak passage") independently of each other.

Use the adjustment screw on the top cover to regulate the maximum flowrate.

Use the adjustment screw on the bottom cover to regulate the minimum flowrate.

If the minimum flowrate is set to zero the equipment gives steam-tight shut-off.

Both adjustment screws feature the same components. The following instructions refer to the respective adjustment screw.

Limiting the maximum flowrate

To ensure that the equipment discharges condensate as continuously as possible you have to reduce the maximum flowrate.

To do so you must limit the valve travel in the opening direction.

The adjustors for setting the maximum flowrate are located on top of the equipment.

To ascertain the required number of turns of the adjustment screw proceed as follows:

- Determine the ratio of the desired maximum flowrate to the flowrate set at our factory.
- Refer to the lift restriction chart to ascertain the number of turns of the adjustment screw that corresponds to this ratio.

The capacity charts are shown in section "Capacity Charts" on page 56.

The lift restriction charts are shown in section "Lift-Restriction Charts" from page 58 onwards.

Example

This example shows how to determine the maximum flowrate for equipment with DN 65 or DN 80.

The charts shown in this example are reduced in size. Use the charts in original size to ascertain the required setting.

A max. flowrate of 26 t/h for hot fluid and a differential pressure of 1.5 bar is desired.

Using the capacity chart for hot fluid you can determine that for a differential pressure of 1.5 bar the factory-set flowrate is 31 t/h.

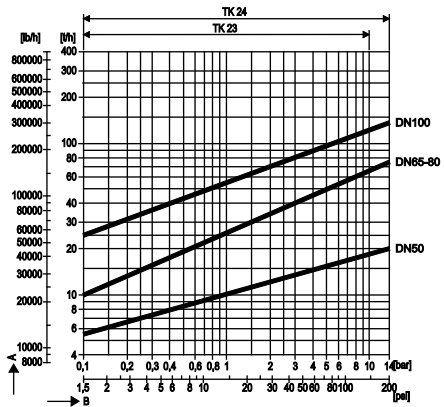

This yields a ratio of $(26 \times 100)/31 = 84\%$.

According to the lift-restriction chart a ratio of 84% (line "A") corresponds to 2¼ turns to the right of the adjustment screw.

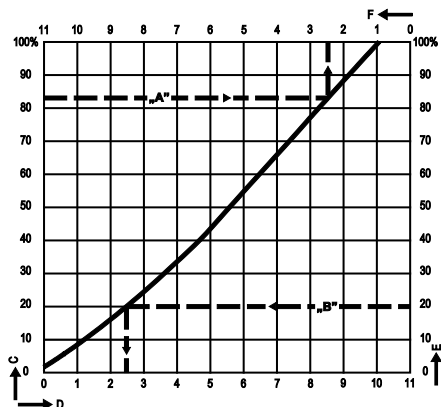

- Make sure that the equipment is depressurized, cooled down to room temperature and free from fluid.
- To reduce the pressure through the bore in the cover slowly loosen the sealing plug by two turns (10).
- Remove the cap nut (1).
- Remove the outer gasket (26) from the adjustment screw.
- Remove the hexagon nut (25).
- Remove the inner gasket (26) from the adjustment screw.
- Screw out the upper adjustment screw (11) until a resistance is felt.

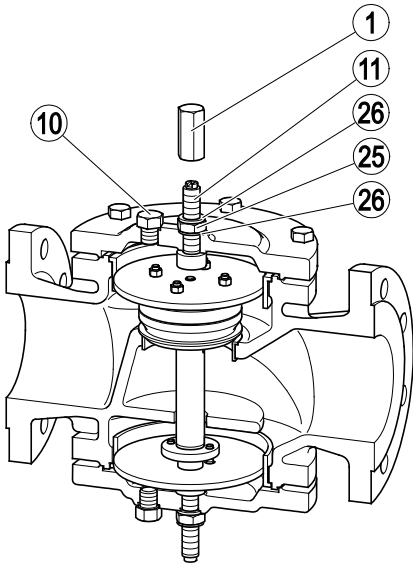
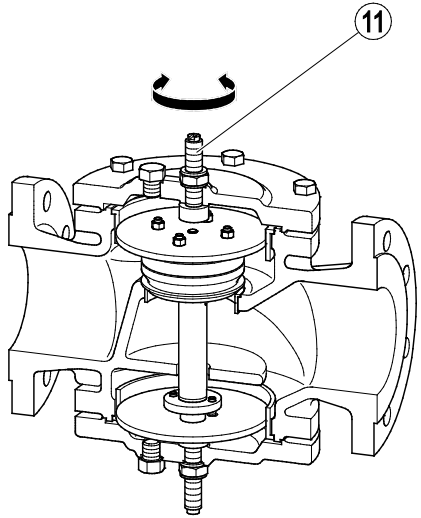

- Turn the upper adjustment screw (11) by the required number of turns.

Attention!

Equipment may leak if the gasket is damaged.

- Replace all gaskets that you loosen during your work.
- Use only new gaskets of the same type.

- Put the new inner gasket (26) onto the top adjustment screw (11).
- Put the hexagon nut (25) onto the adjustment screw.
- Make sure that the adjustment screw cannot rotate.

For this purpose you can for example push the tip of a screwdriver into the slot of the adjustment screw.

The torques required for tightening the hexagon nut (25) and the cap nut (1) depend on the equipment type.

- ▶ TK 23 requires 20 Nm.
- ▶ TK 24 requires 30 Nm.
- Fasten the hexagon nut with the specified torque.
- Put the new outer gasket (26) onto the upper adjustment screw.
- Screw the cap nut (1) onto the upper adjustment screw.
- Fasten the cap nut with the specified torque.
- Insert the new gasket (27) into the bore of the upper sealing plug.
- Put the sealing plug (10) into the bore.

The torque for the sealing plug depends on the equipment type.

- ▶ TK 23 requires 20 Nm.
- ▶ TK 24 requires 40 Nm.
- Fasten the sealing plug with the specified torque.

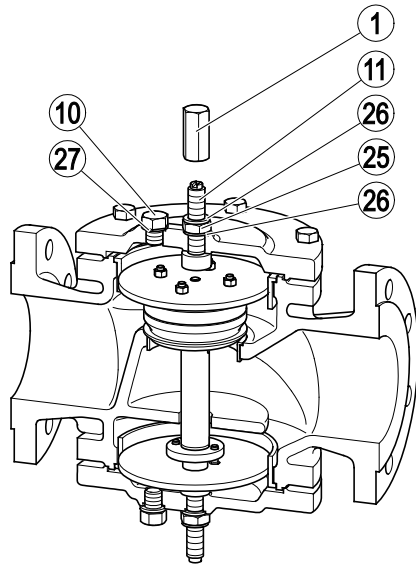

Adjusting a minimum flowrate

To adjust a minimum flowrate (partial flow, "leak passage") change the valve travel in the closing direction.

The adjustors for setting the minimum flowrate are located at the bottom of the equipment.

To ascertain the required number of turns of the adjustment screw proceed as follows:

- Determine the ratio of the desired minimum flowrate to the flowrate set at our factory.
- Refer to the lift restriction chart to ascertain the number of turns of the adjustment screw that corresponds to this ratio.

The capacity charts are shown in section "*Capacity Charts*" on page 56.

The lift restriction charts are shown in section "*Lift-Restriction Charts*" from page 58 onwards.

Example

This example shows how to determine the minimum flowrate for equipment with DN 65 or DN 80.

The charts shown in this example are reduced in size. Use the charts in original size to ascertain the required setting.

A minimum flowrate of 6.5 t/h for hot fluid and a differential pressure of 1.5 bar is desired.

Using the capacity chart for hot fluid you can determine that for a differential pressure of 1.5 bar the factory-set flowrate is 31 t/h.

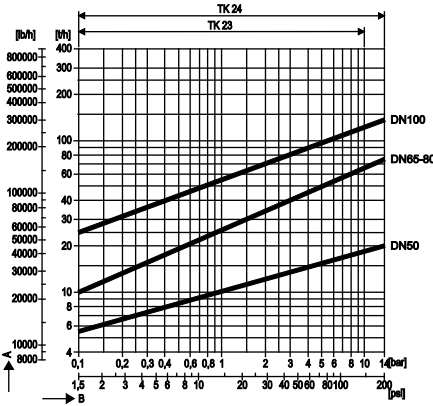

This yields a ratio of $(6.5 \times 100)/31 = 21\%$.

According to the lift-restriction chart a ratio of 21% (line "B") corresponds to 2½ turns to the right of the adjustment screw.

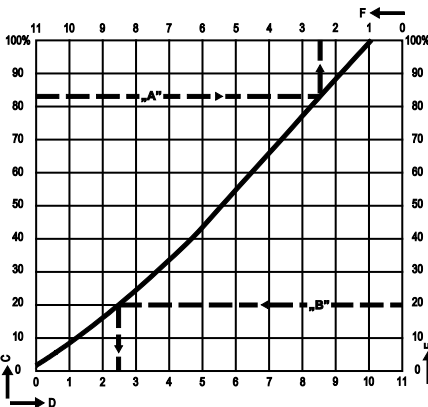

- Make sure that the equipment is depressurized, cooled down to room temperature and free from fluid.
- To reduce the pressure through the bore in the cover slowly loosen the sealing plug by two turns (10).
- Remove the lower cap nut (1).
- Remove the outer gasket (26) from the lower adjustment screw.
- Remove the hexagon nut (25).
- Remove the inner gasket (26) from the lower adjustment screw.
- Screw out the adjustment screw (12) until a resistance is felt.

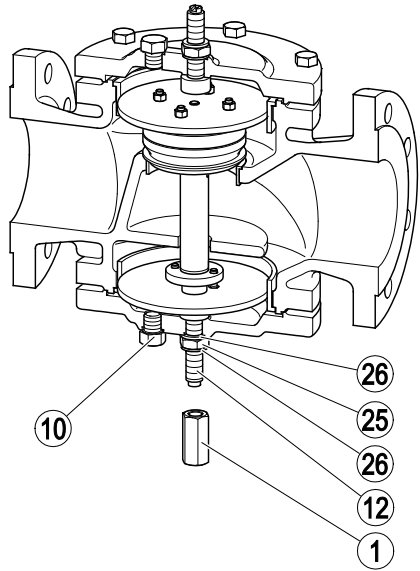

- Screw in the lower adjustment screw (12) by the number of turns specified in the chart.

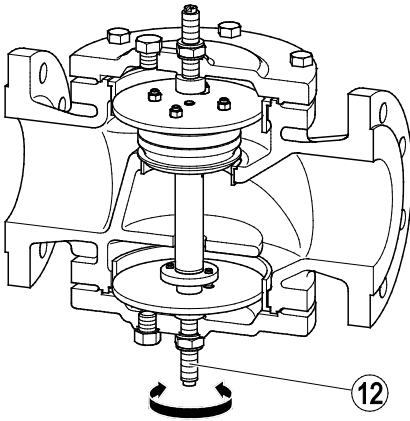

Attention!

Equipment may leak if the gasket is damaged.

- Replace all gaskets that you loosen during your work.
- Use only new gaskets of the same type.

- Put the new inner gasket (26) onto the lower adjustment screw (12).
- Put the hexagon nut (25) onto the adjustment screw.
- Make sure that the adjustment screw cannot rotate.

For this purpose you can for example push the tip of a screwdriver into the slot of the adjustment screw.

The torques required for tightening the hexagon nut (25) and the cap nut (1) depend on the equipment type.

- ▶ TK 23 requires 20 Nm.
- ▶ TK 24 requires 30 Nm.

- Fasten the hexagon nut with the specified torque.
- Put the new outer gasket (26) onto the lower adjustment screw.
- Screw the cap nut (1) onto the adjustment screw.
- Fasten the cap nut with the specified torque.
- Put a new gasket (27) over the thread of the sealing plug.
- Put the sealing plug (10) into the bore.

The torque for the sealing plug depends on the equipment type.

- ▶ TK 23 requires 20 Nm.
- ▶ TK 24 requires 40 Nm.

- Fasten the sealing plug with the specified torque.

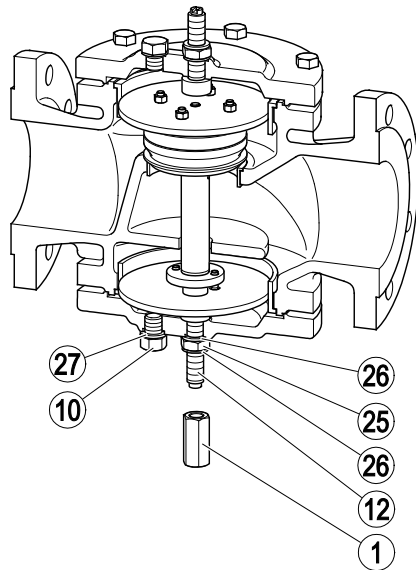

Adjustment to give steam-tight shut-off

To prevent steam loss you can adjust the equipment to give steam-tight shut-off. To do so you have to set the minimum flowrate to zero.

Attention!

Malfunctions due to banking-up of condensate.

Limiting the maximum flowrate changes the factory-set leak passage ("partial flow"). The equipment closes as soon as steam arrives. Note that the responsiveness of the membrane regulator is reduced due to the lack of a partial flow. As a result condensate may bank up.

- Make sure that the process in the higher-level plant system is not impaired by banking-up of condensate.

To ensure that the equipment gives steam-tight shut-off the following work must be performed on the lower adjustment screw:

- Make sure that the equipment is depressurized, cooled down to room temperature and free from fluid.
- To reduce the pressure through the bore in the cover slowly loosen the sealing plug by two turns (10).
- Remove the cap nut (1).
- Remove the outer gasket (26) from the adjustment screw.
- Remove the hexagon nut (25).
- Remove the inner gasket (26) from the adjustment screw.
- Screw out the adjustment screw (12) until a resistance is felt.

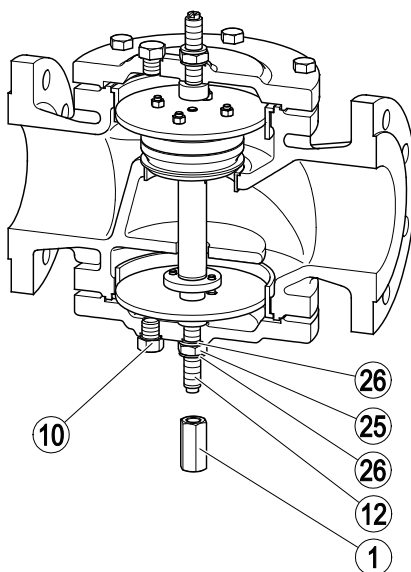

Attention!

Equipment may leak if the gasket is damaged.

- Replace all gaskets that you loosen during your work.
- Use only new gaskets of the same type.

- Put the new inner gasket (26) onto the lower adjustment screw (12).
- Put the hexagon nut (25) onto the adjustment screw.
- Make sure that the adjustment screw cannot rotate.

For this purpose you can for example push the tip of a screwdriver into the slot of the adjustment screw.

The torques required for tightening the hexagon nut (25) and the cap nut (1) depend on the equipment type.

- ▶ TK 23 requires 20 Nm.
- ▶ TK 24 requires 30 Nm.
- Fasten the hexagon nut with the specified torque.
- Put the new outer gasket (26) onto the lower adjustment screw.
- Screw the cap nut (1) onto the adjustment screw.
- Fasten the cap nut with the specified torque.
- Put a new gasket (27) over the thread of the sealing plug.
- Put the sealing plug (10) into the bore.

The torque for the sealing plug depends on the equipment type.

- ▶ TK 23 requires 20 Nm.
- ▶ TK 24 requires 40 Nm.
- Fasten the sealing plug with the specified torque.

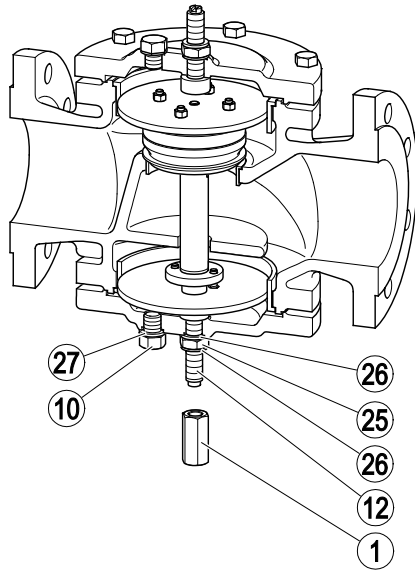

Restoring default factory settings

To re-adjust the factory settings of the flowrates proceed as follows:

Restoring the factory set minimum flowrate

- Make sure that the equipment is depressurized, cooled down to room temperature and free from fluid.
- To reduce the pressure through the bore in the cover slowly loosen the sealing plug by two turns (10).
- Remove the lower cap nut (1).
- Remove the outer gasket (26) from the lower adjustment screw.
- Remove the hexagon nut (25).
- Remove the inner gasket (26) from the lower adjustment screw.

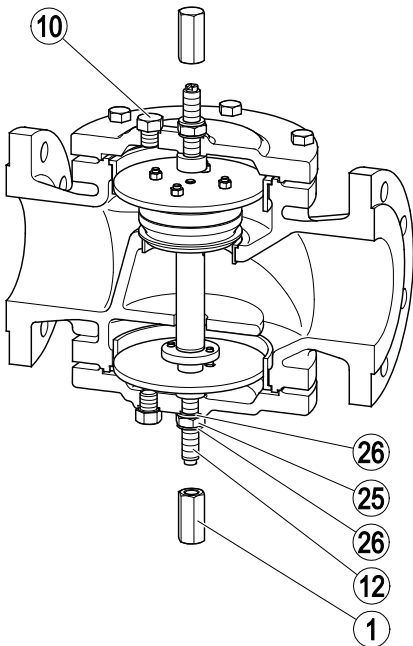

- Screw out the adjustment screw (12) until a resistance is felt.
- Remove the upper sealing plug (10).
- Take the gasket (27) out of the bore for the sealing plug.
- Insert a screwdriver through the bore for the upper sealing plug and push down the dampening plate (22).
- Keep pushing it down until the cone (19) rests on the seat sleeve (28).
- Hold the dampening plate securely in this position.
- Screw in the adjustment screw until you can feel that the dampening plate starts to lift.
- Screw the adjustment screw half a turn further in.

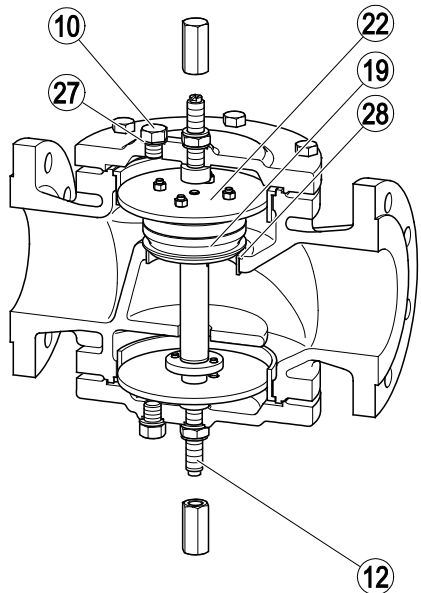

Attention!

Equipment may leak if the gasket is damaged.

- Replace all gaskets that you loosen during your work.
- Use only new gaskets of the same type.

- Put the new inner gasket (26) onto the lower adjustment screw (12).
- Put the hexagon nut (25) onto the adjustment screw.
- Make sure that the adjustment screw cannot rotate.

For this purpose you can for example push the tip of a screwdriver into the slot of the adjustment screw.

The torques required for tightening the hexagon nut (25) and the cap nut (1) depend on the equipment type.

- ▶ TK 23 requires 20 Nm.
- ▶ TK 24 requires 30 Nm.
- Fasten the hexagon nut with the specified torque.
- Put the new outer gasket (26) onto the lower adjustment screw.
- Screw the cap nut (1) onto the adjustment screw.
- Fasten the cap nut with the specified torque.
- Put a new gasket (27) over the thread of the sealing plug.
- Put the sealing plug (10) into the bore.

The torque for the sealing plug depends on the equipment type.

- ▶ TK 23 requires 20 Nm.
- ▶ TK 24 requires 40 Nm.
- Fasten the sealing plug with the specified torque.

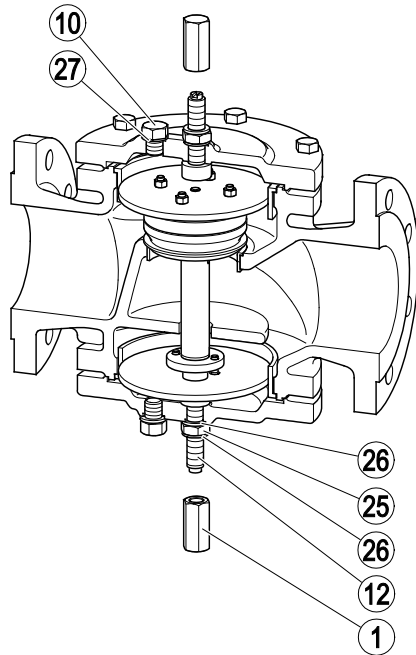

Restoring the factory set maximum flowrate

- Make sure that the equipment is depressurized, cooled down to room temperature and free from fluid.
- To reduce the pressure through the bore in the cover slowly loosen the sealing plug by two turns (10).
- Remove the upper cap nut (1).
- Remove the outer gasket (26) from the upper adjustment screw.
- Remove the upper hexagon nut (25).
- Remove the inner gasket (26) from the upper adjustment screw.
- Screw out the upper adjustment screw (11) until a resistance is felt.
- Screw the adjustment screw half a turn further in.
- Put a new inner gasket (26) onto the upper adjustment screw.
- Make sure that the adjustment screw cannot rotate.

For this purpose you can for example push the tip of a screwdriver into the slot of the adjustment screw.

The torques required for tightening the hexagon nut (25) and the cap nut (1) depend on the equipment type.

- ▶ TK 23 requires 20 Nm.
- ▶ TK 24 requires 30 Nm.
- Fasten the hexagon nut with the specified torque.
- Put a new outer gasket (26) onto the upper adjustment screw.
- Screw the cap nut (1) onto the adjustment screw.
- Fasten the cap nut with the specified torque.
- Remove the sealing plug (10).
- Take the gasket (27) out of the bore for the sealing plug.
- Insert a new gasket into the bore of the sealing plug.
- Put the sealing plug into the bore.

The torque for the sealing plug depends on the equipment type.

- ▶ TK 23 requires 20 Nm.
- ▶ TK 24 requires 40 Nm.
- Fasten the sealing plug with the specified torque.

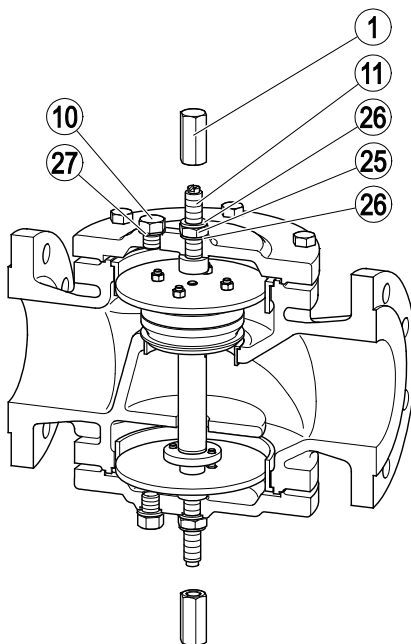

Operation

Do not work on the equipment while it is operating.

After operation

Removing external dirt deposits

- To remove dirt deposits rinse the equipment with fresh water and wipe it with a clean, lint-free cloth.
- To remove any persistent residues use a cleaning agent that is suitable for the material and carefully wipe the equipment with a clean, lint-free cloth.

Maintaining the equipment

For work on the equipment you will need the following tools:

- ▶ Torque spanner (US: wrench) 4-40 Nm
- ▶ Torque spanner (US: wrench) 20-120 Nm
- ▶ 2 Spanners A. F. 8 mm
- ▶ 2 Spanners A. F. 19 mm (TK 23) or 24 mm (TK 24)
- ▶ Screwdriver 6 mm
- ▶ Screwdriver 10 mm

Cleaning the equipment

Check the equipment at regular intervals for contamination. The intervals depend on the amount of dirt in the system. The operator must determine the maintenance intervals.

Normally you do not have to clean the internal parts of the equipment.

To clean the equipment completely take off the cover and remove the control unit.

- To remove dirt deposits rinse the equipment with fresh water and wipe it with a clean, lint-free cloth.
- To remove any persistent residues use a cleaning agent that is suitable for the material

and carefully wipe the equipment with a clean, lint-free cloth.

- Remove any parts that are dirty and cannot be cleaned properly.

Removing cover of equipment with DN 50



DANGER

Personnel working on pipes are exposed to safety risks and may suffer severe injuries, poisoning or even loss of life.

- Make sure that no hot or hazardous fluid is in the equipment or the pipes.
- Make sure that the pipes upstream and downstream of the equipment are depressurised.
- Make sure that the installation is switched off and protected against unauthorised or unintended activation.
- Make sure that the equipment and the pipes have cooled down to room temperatures.
- Wear protective clothing that is suitable for the fluid and, if necessary, wear protective gear.

For more information on suitable protective clothing and safety gear refer to the safety data sheet of the fluid in question.

- Make sure that the equipment is depressurized, cooled down to room temperature and free from fluid.

- To reduce the pressure through the bore in the cover slowly loosen the sealing plug by two turns (10).
- Remove the cap nut (1).
- Remove the outer gasket (26).
- Remove the hexagon nut (25).
- Remove the inner gasket (26).
- Remove the hexagon-head cap bolts (2) and the hexagon nuts (29).
- Remove the sealing plug (10).
- Remove the gasket (27).

You can now remove the cover together with the attached adjustment screw (9) and the regulator unit from the body.

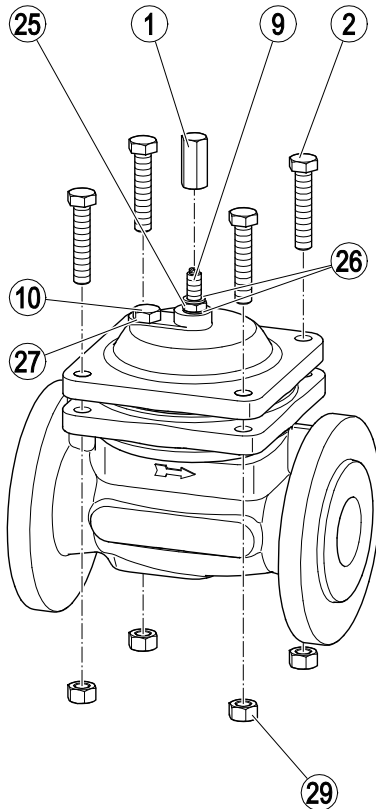

Attention!

A deformed sleeve can cause malfunctions.

- When removing the cover take care that the sleeve does not fall out of the body.
-
- Take the cover (3) together with the regulator unit (4) out of the body.
 - Remove the body gasket (31).
 - Make sure that the sleeve (30) cannot fall out of the body.
 - Unscrew the adjustment screw (9) with the regulator unit (4) attached to it from the cover.

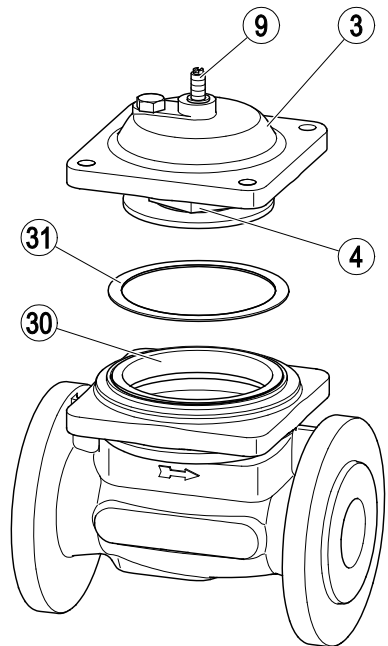

Removing cover of equipment with DN 65 - 100

Remove the two covers one after the other. The following section describes how to remove the upper cover. Remove the lower cover in the same way. The following drawings show the components of both covers.



DANGER

Personnel working on pipes are exposed to safety risks and may suffer severe injuries, poisoning or even loss of life.

- Make sure that no hot or hazardous fluid is in the equipment or the pipes.
- Make sure that the pipes upstream and downstream of the equipment are depressurised.
- Make sure that the installation is switched off and protected against unauthorised or unintended activation.
- Make sure that the equipment and the pipes have cooled down to room temperatures.
- Wear protective clothing that is suitable for the fluid and, if necessary, wear protective gear.

For more information on suitable protective clothing and safety gear refer to the safety data sheet of the fluid in question.

- Make sure that the equipment is depressurized, cooled down to room temperature and free from fluid.
- To reduce the pressure through the bore in the cover slowly loosen the sealing plug by two turns (10).
- Remove the cap nut (1).
- Remove the outer gasket (26).
- Remove the hexagon nut (25).
- Remove the inner gasket (26).
- Remove the hexagon-head cap bolts (2) and the hexagon nuts (29).

- Remove the upper sealing plug (10).
- Remove the gasket (27).

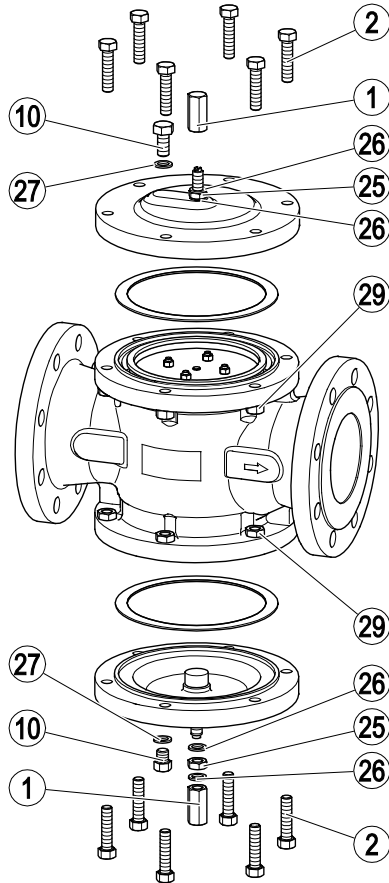

Attention!

A deformed sleeve can cause malfunctions.

- When removing the cover take care that the sleeve does not fall out of the body.

- Take the cover (3) off the body.
- Remove the body gasket (31).
- Make sure that the sleeve (30) cannot fall out of the body.
- Unscrew the adjustment screw (11 or 12) from the cover.
- To remove the second cover repeat these steps.

The regulator unit (4) is now accessible. To remove the regulator unit proceed as describe in section "*Exchanging the regulator unit of equipment with DN 65 - 100*" from page 44 onwards.

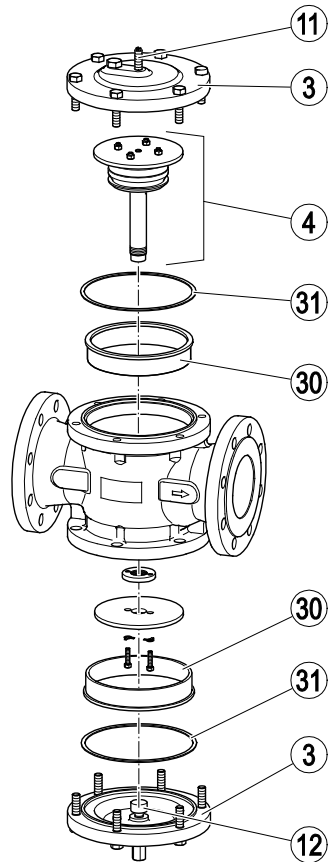

Cleaning and checking the membrane regulator capsule

The removal method for the membrane regulator capsule depends on the equipment type.

How to remove the membrane regulator capsule of equipment with DN 50 is described on page 45.

How to remove the membrane regulator capsule of equipment with DN 65 - 100 is described on page 46.

- Remove the membrane regulator capsule as described in the respective section.
- Use a depth gauge to check the dimension x of the membrane regulator capsule as shown in the following drawing.



The membrane regulator capsule is intact if dimension x exceeds 4.0 mm.

- Discard and replace defective membrane regulator capsule with a new one.

Mounting cover of equipment with DN 50

Attention!

Equipment may leak if the gasket is damaged.

- It is therefore essential that you always insert a new gasket before re-attaching the cover.
- Make sure that the cover is not tilted or skewed when refitted.

- Clean the gasket surfaces of the cover and body.
- Apply a light smear of lubricant to the threads of the bolts and the underside the bolt heads.

The lubricant must have the same properties as OKS 217.

- Put a new body gasket (31) onto the sleeve (30).
- Screw the adjustment screw (9) with the regulator unit attached to it into the cover (3) and stop shortly before it hits the stop.
- Carefully place the cover with the regulator unit (4) onto the body.
- Make sure that the dampening plate does not get jammed in the sleeve.

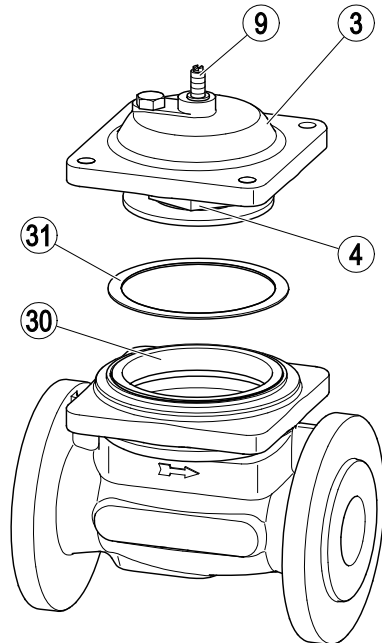

- Fasten the hexagon-head cap bolts (2) and the hexagon nuts (29) hand tight.

The torque for the hexagon-head cap bolts depends on the equipment type.

- ▶ Equipment of type TK 23 requires a torque of 40 Nm.
- ▶ Equipment of type TK 24 requires a torque of 55 Nm.

- Fasten the hexagon nuts with the specified torque.
- Re-adjust the equipment settings as described in section "*Adapting settings*" from page 13 onwards.
- Put the new inner gasket (26) onto the adjustment screw.
- Put the hexagon nut (25) onto the adjustment screw (9).
- Make sure that the adjustment screw cannot rotate.

For this purpose you can for example push the tip of a screwdriver into the slot of the adjustment screw.

- Tighten the hexagon nut (25) with a torque of 30 Nm.
- Put the new outer gasket (26) onto the adjustment screw.
- Screw the cap nut (1) onto the adjustment screw.
- Tighten the cap nut with a torque of 30 Nm.
- Insert the new gasket (27) into the bore of the sealing plug.
- Put the sealing plug (10) into the bore.

The torque for the sealing plug depends on the equipment type.

- ▶ Equipment of type TK 23 requires a torque of 30 Nm.
- ▶ Equipment of type TK 24 requires a torque of 40 Nm.
- Fasten the sealing plug with the specified torque.

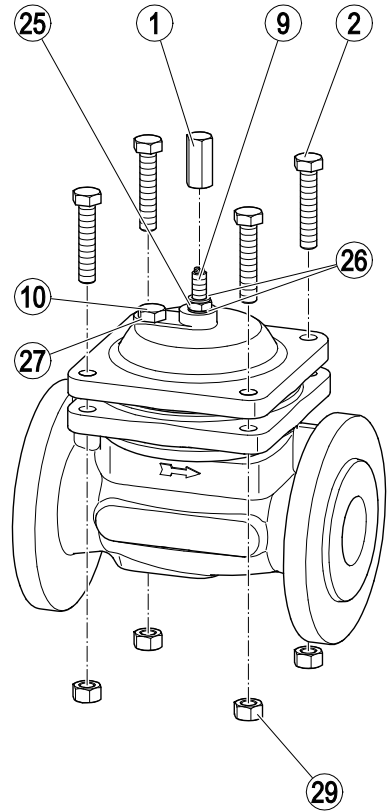

After mounting the cover you have to readjust the settings of the equipment.

- Proceed as described in section "*Adapting settings*" from page 13 onwards.

Mounting cover of equipment with DN 65 - 100

Attention!

Equipment may leak if the gasket is damaged.

- It is therefore essential that you always insert a new gasket before re-attaching the cover.
- Make sure that the cover is not tilted or skewed when refitted.

- Clean the gasket surfaces of the cover and body.
- Apply a light smear of lubricant to the threads of the bolts and the underside the bolt heads.

The lubricant must have the same properties as OKS 217.

Mount the two covers one after the other. The following section describes how to mount the upper cover with the adjustment screw (11). Mount the lower cover with the adjustment screw (12) in the same way. The following drawings show the components of both covers.

- Put a new body gasket (31) onto the sleeve (30).
- Screw the adjustment screw (11) into the cover (3) and stop shortly before it hits the stop.
- Make sure that the regulator unit (4) is securely fixed in place.
- Carefully place the cover with the regulator unit onto the body.

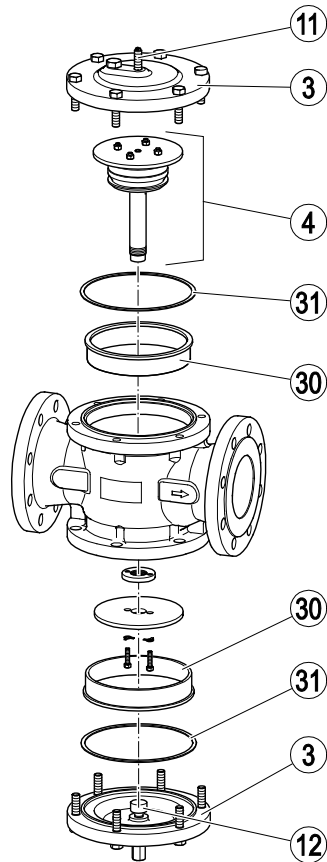

- Fasten the hexagon-head cap bolts (2) and the hexagon nuts (29) hand tight.

The torque for the hexagon-head cap bolts depends on the equipment type.

- ▶ Equipment of type TK 23 requires a torque of 35 Nm.
 - ▶ Equipment of type TK 24, DN 65–80 requires a torque of 50 Nm.
 - ▶ Equipment of type TK 24, DN 100 requires a torque of 40 Nm.
- Fasten the hexagon nuts with the specified torque.
 - Put the new inner gasket (26) onto the adjustment screw.
 - Put the hexagon nut (25) onto the adjustment screw.
 - Make sure that the adjustment screw cannot rotate.

For this purpose you can for example push the tip of a screwdriver into the slot of the adjustment screw.

The torque for the hexagon nut (25) depends on the equipment type.

- ▶ Equipment of type TK 23 requires a torque of 20 Nm.
- ▶ Equipment of type TK 24 requires a torque of 30 Nm.

- Fasten the hexagon nut with the specified torque.
- Put the new outer gasket (26) onto the adjustment screw.
- Screw the cap nut (1) onto the adjustment screw.

The torque for the cap nut depends on the equipment type.

- ▶ Equipment of type TK 23 requires a torque of 20 Nm.
- ▶ Equipment of type TK 24 requires a torque of 30 Nm.

- Tighten the cap nut (1) to the specified torque.

- Insert the new gasket (27) into the bore of the sealing plug.
- Put the sealing plug (10) into the bore.

The torque for the sealing plug depends on the equipment type.

- ▶ Equipment of type TK 23 requires a torque of 20 Nm.
- ▶ Equipment of type TK 24 requires a torque of 40 Nm.

- Fasten the sealing plug with the specified torque.

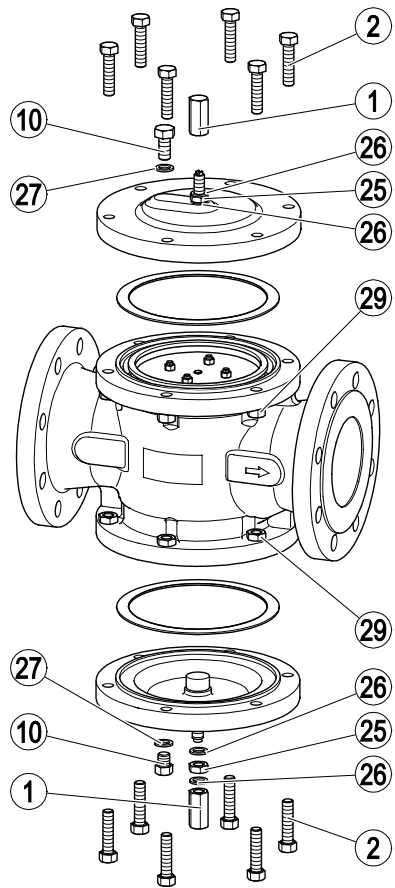



After mounting the cover you have to readjust the settings of the equipment.

- Proceed as described in section "Adapting settings" from page 13 onwards.

Servicing the equipment and installing spare parts

You may exchange the following component parts in case of wear or damage:

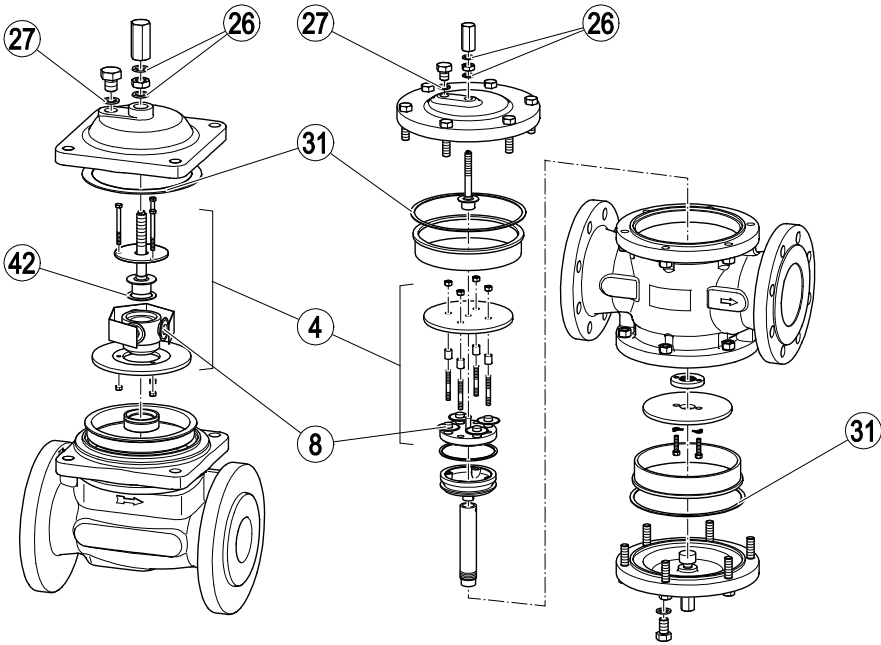

Spare Parts

Item no.	Designation	Stock code #		
		DN50	DN65–80	DN100
26, 27, 31, 42	Gasket set <ul style="list-style-type: none"> ▶ 1 Body gasket (31) ▶ 1 Gasket for regulator unit (42) ▶ 4 Gaskets (26/27) 	377364	–	–
26, 27, 31	Gasket set <ul style="list-style-type: none"> ▶ 1 Body gasket (31) ▶ 7 Gaskets (26/27) 	–	377365	377366

Item no.	Designation	Stock code #		
		DN50	DN65–80	DN100
8, 26, 27, 31	Capsule set 0H2 • 3 Membrane regulator capsules 0H2 (8) • 1 Body gasket (31) • 4 Gaskets (26/27)	377234	–	–
8, 26, 27, 31	Capsule set 0H2 • 4 Membrane regulator capsules 0H2 (8) • 2 Body gasket (31) • 7 Gaskets (26/27)	–	377235	377236
8, 26, 27, 31	Capsule set 5H2 • 3 Membrane regulator capsules 5H2 (8) • 1 Body gasket (31) • 4 Gaskets (26/27)	377237	–	–
8, 26, 27, 31	Capsule set 5H2 • 4 Membrane regulator capsules 5H2 (8) • 2 Body gasket (31) • 7 Gaskets (26/27)	–	377238	377239
4, 26, 27, 31	Regulator set • 1 Regulator unit 5H2 (4) • 1 Body gasket (31) • 3 Gaskets (26/27)	379914	–	–
4, 26, 27, 31	Regulator set • 1 Regulator unit 5H2 (4) • 2 Body gasket (31) • 6 Gaskets (26/27)	–	379915	379916

For work on the equipment you will need the following tools:

- ▶ Torque spanner (US: wrench) 4-40 Nm
- ▶ Torque spanner (US: wrench) 20-120 Nm
- ▶ 2 Spanners A. F. 8 mm
- ▶ 2 Spanners A. F. 19 mm (TK 23) or 24 mm (TK 24)
- ▶ Screwdriver 6 mm
- ▶ Screwdriver 10 mm

Exchanging the regulator unit of equipment with DN 50

- Remove the cover as described in section "*Removing cover of equipment with DN 50*" from page 34 onwards.

The regulator set comprises the whole regulator unit with the adjustment screw attached to it.

- Replace the regulator unit with the attached adjustment screw with a new one.
- Attach the cover to the body as described in section "*Mounting cover of equipment with DN 50*" from page 38 onwards.

Exchanging the regulator unit of equipment with DN 65 - 100

- Remove the cover as described in section "*Removing cover of equipment with DN 65 - 100*" from page 36 onwards.

To take out the regulator unit (4) you have to remove the lift plate (32).

- Bend open the retaining metal straps (33).
- Remove the hexagon-head cap bolts (34).
- Detach the lift plate (32) from the regulator unit.
- Unscrew the washer nut (35) from the stem of the regulator unit.
- Lift the regulator unit (21) off the body.
- Put a new regulator unit into the body.
- Screw the washer nut (35) onto the stem of the regulator unit.

The stop dog for the lift plate at the lower end of the stem must protrude approx. 3 to 4 mm after positioning the lift plate in place.

- Put the lift plate (32) onto the stem of the regulator unit.
- Turn the lift plate until the bores in the lift plate and in the washer nut are aligned one on top of the other.
- Put the retaining metal straps (33) onto the threads of the hexagon-head cap bolts.
- Screw the hexagon-head cap bolts (34) into the bores.
- Tighten the hexagon-head cap bolts with a torque of 5 Nm.
- Bend back the retaining metal straps.

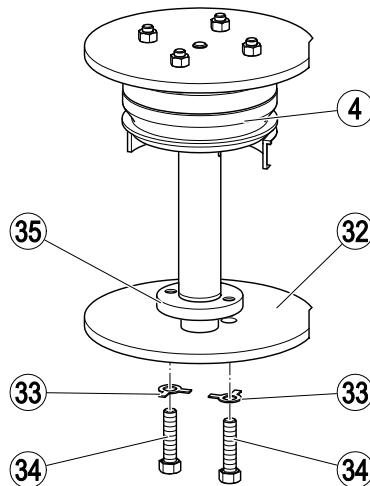

- Attach the cover to the body as described in section "*Mounting cover of equipment with DN 65 - 100*" from page 40 onwards.

Exchanging the membrane regulator capsule of equipment with DN 50



⚠ DANGER

Personnel working on pipes are exposed to safety risks and may suffer severe injuries, poisoning or even loss of life.

- Make sure that no hot or hazardous fluid is in the equipment or the pipes.
- Make sure that the pipes upstream and downstream of the equipment are depressurised.
- Make sure that the installation is switched off and protected against unauthorised or unintended activation.
- Make sure that the equipment and the pipes have cooled down to room temperatures.
- Wear protective clothing that is suitable for the fluid and, if necessary, wear protective gear.

For more information on suitable protective clothing and safety gear refer to the safety data sheet of the fluid in question.

- Remove the cover as described in section "Removing cover of equipment with DN 50" from page 34 onwards.
- Remove the hexagon nuts (43) and the hexagon-head cap bolts (39).

You can now disassemble the regulator unit.

- Take the adjustment screw (9) out of the regulator unit.
- Remove the guide plate (40).
- Remove the sleeve (41) and the gasket (42) from the cone (19).
- Detach the capsule support (36) from the regulator unit.
- Detach the membrane regulator capsule (8) from the seat (37).

- To attach a new membrane regulator capsule to the regulator unit press the capsule into the seat until it snaps into place.
- Push the capsule support onto the lift plate until it hits the stop (21).

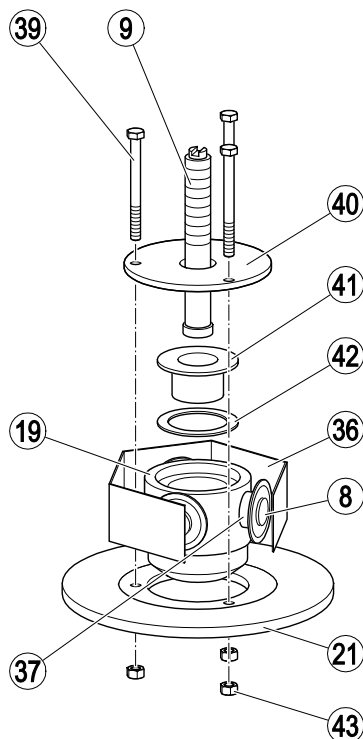

- Apply a light smear of lubricant to the threads of the bolts and the underside the bolt heads.

The lubricant must have the same properties as OKS 217.

Attention!

Equipment may leak if the gasket is damaged.

- Replace all gaskets that you loosen during your work.
- Use only new gaskets of the same type.

- Replace the gasket of the regulator unit with a new one of the same type.
- Assemble the regulator unit in reverse order of the disassembling procedure:

Attention!

Equipment may not work properly or get damaged if screws, nuts or bolts are tightened with the wrong torques.

- Tighten the screwed union to the following torque:
-
- Tighten the hexagon nuts on the hexagon-head cap bolts with a torque of 4 Nm.
 - Attach the cover to the body as described in section "*Mounting cover of equipment with DN 50*" from page 38 onwards.

Exchanging the membrane regulator capsule of equipment with DN 65 -100



DANGER

Personnel working on pipes are exposed to safety risks and may suffer severe injuries, poisoning or even loss of life.

- Make sure that no hot or hazardous fluid is in the equipment or the pipes.
- Make sure that the pipes upstream and downstream of the equipment are depressurised.
- Make sure that the installation is switched off and protected against unauthorised or unintended activation.
- Make sure that the equipment and the pipes have cooled down to room temperatures.
- Wear protective clothing that is suitable for the fluid and, if necessary, wear protective gear.

For more information on suitable protective clothing and safety gear refer to the safety data sheet of the fluid in question.

- Remove the upper cover as described in section "*Removing cover of equipment with DN 65 - 100*" from page 36 onwards.

To exchange the regulator capsules you do not have to remove the lower cover.

- Remove the hexagon nuts (38) on the dampening plate (22).
- Lift the dampening plate (21) off the body.
- Detach the membrane regulator capsule (8) from the seat (37).
- To attach the membrane regulator capsule to the nozzle insert press the capsule into the seat until it snaps into place.
- Put the dampening plate (22) onto the body, making sure that the stud bolts of the regulator unit protrude through the bore.
- Put the hexagon nuts (38) onto the stud bolts.
- Tighten the hexagon nuts with a torque of 32 Nm.

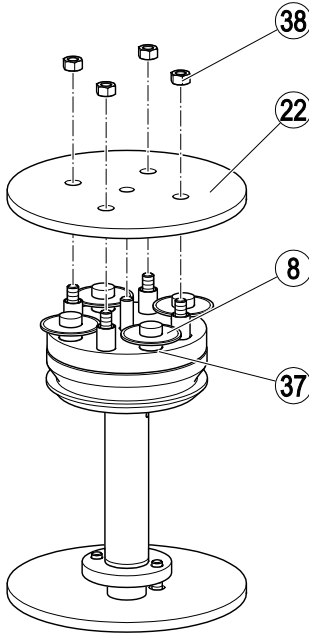

- Attach the cover to the body as described in section "*Mounting cover of equipment with DN 65 - 100*" from page 40 onwards.

Exchanging body gasket



DANGER

Personnel working on pipes are exposed to safety risks and may suffer severe injuries, poisoning or even loss of life.

- Make sure that no hot or hazardous fluid is in the equipment or the pipes.
- Make sure that the pipes upstream and downstream of the equipment are depressurised.
- Make sure that the installation is switched off and protected against unauthorised or unintended activation.
- Make sure that the equipment and the pipes have cooled down to room temperatures.
- Wear protective clothing that is suitable for the fluid and, if necessary, wear protective gear.

For more information on suitable protective clothing and safety gear refer to the safety data sheet of the fluid in question.

The removal method for the cover depends on the equipment type.

How to remove the cover of equipment with DN 50 is described on page 34.

How to remove the cover of equipment with DN 65 - 100 is described on page 36.

The following section shows equipment with DN 50.

- Remove the cover as described in the respective section.
- Replace the body gasket (31) with a new one.

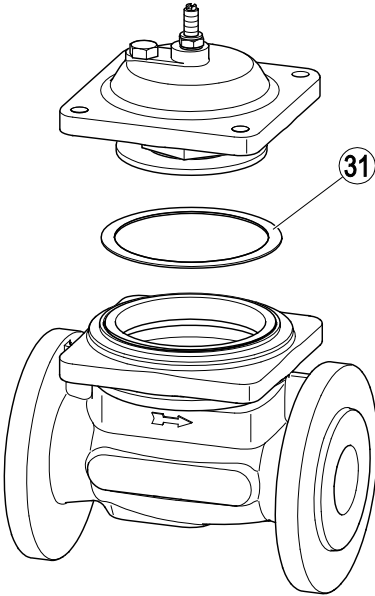

The mounting method for the cover depends on the equipment type.

How to mount the cover of equipment with DN50 is described on page 38.

How to mount the cover of equipment with DN 65 - 100 is described on page 40.

- Attach cover to the equipment as described in the respective section.

Troubleshooting

Problem	Cause	Remedy
The steam trap is cold or only hand-hot.	The shut-off valves for condensate inlet or outlet are closed.	Open the shut-off valves.
	The condensate inlet or outlet is dirt clogged.	Clean the pipes. Clean the equipment.
The steam trap is blowing off live steam.	The steam trap is adjusted to obtain a leak passage (minimum flowrate).	Adjust the steam trap to give steam-tight shut-off.
	The membrane regulator capsules are dirty. There are dirt deposits in the equipment.	Clean the membrane regulator capsules. Clean the equipment. Replace the membrane regulator capsules with new ones.
	The membrane regulator capsules are worn. The seat is leaking.	Replace the membrane regulator capsules with new ones.
	The bypass is open.	Close the bypass.
Insufficient condensate discharge. Insufficient thermal output of the user.	The shut-off valves for condensate inlet or outlet are closed.	Open the shut-off valves.
	The condensate inlet or outlet is dirt clogged.	Clean the pipes. Clean the equipment. Replace the membrane regulator capsules with new ones.
	Steam pressure and condensate flowrate fluctuate considerably. The pressure upstream of the steam trap is too low for the used trap type.	Use a different steam trap type. Contact the manufacturer to find out which trap type is the most suitable for your application.
	The steam trap is undersized.	Use a steam trap with a larger condensate discharge capacity.

Problem	Cause	Remedy
	The differential pressure is too small.	Increase the steam pressure. Lower the pressure in the condensate line. Check the size of the condensate line. Install a steam trap with a larger condensate discharge capacity or a condensate return unit.
	The distance between the drain point and the steam trap is too small.	Install the uninsulated steam trap approx. 1 - 2 m away from the drain point. Do not insulate the condensate line and lay it with a gradient so that the condensate is free to fall towards the steam trap.
	The condensate line does not have a slight fall from the drain point towards the steam trap. The condensate is lifted upstream of the steam trap.	Lay the condensate line with a gradient so that the condensate is free to fall towards the steam trap. Change the orientation of the condensate line.
	The steam trap is adjusted to give steam-tight shut-off.	Restore the factory setting. If necessary re-adjust the settings of the steam trap.
	The condensate temperature is higher than the service temperature of the steam trap. The regulator does not open or only with a time delay.	If the steam trap or the condensate line is insulated remove the insulation. Use a different steam trap type.
	Insufficient deaeration.	Provide additional deaeration. Use a different steam trap type. Contact the manufacturer to find out which trap type is the most suitable for your application.

Problem	Cause	Remedy
Fluid escapes (equipment is leaking).	The end connections are not tight.	Seal off the end connections (e. g. flanged or screwed ends).
	A gasket on the body is defective.	Replace the gasket with a new one.
	The body has been damaged by corrosion or erosion.	Check the resistance of the body material for the fluid used. Use a steam trap made from a material that is suitable for the fluid used.
	The equipment has been damaged by frost.	Replace the equipment with a new one. When shutting down the installation make sure that the condensate lines and the steam trap are completely drained.
	The equipment has been damaged by waterhammer.	Replace the equipment with a new one. Take appropriate measures to protect the equipment against waterhammer, e. g. by installing suitable non-return valves.

- If faults occur that are not listed above or cannot be corrected, please contact our Technical Service or authorized agency in your country.

Putting the equipment out of operation

Removing harmful substances



DANGER

If the equipment is used in contaminated areas there is a risk of severe injuries or death caused by harmful substances in or on the equipment.

- Only qualified personnel are allowed to perform work on contaminated equipment.
- Always wear the protective clothing prescribed for contaminated areas when working on the equipment.
- Make sure that the equipment is completely decontaminated before carrying out any service work.
- Follow the pertinent instructions for handling the hazardous substances in question.

Qualified personnel must have extensive experience with and a working knowledge of:

- ◆ pertinent rules and regulations concerning handling hazardous substances
- ◆ special regulations for handling the hazardous substances encountered on site
- ◆ using the required personal protective equipment (PPE) and clothing



Caution

Environmental damage may be caused by poisonous fluid residues.

- Before disposing of the equipment make sure that it is clean and free of fluid residues.
 - For the disposal of all materials observe the pertinent legal regulations concerning waste disposal.
-
- Remove all residues from the equipment.
 - For the disposal of all residues observe the pertinent legal regulations concerning waste disposal.

Removing the equipment



DANGER

Personnel working on pipes are exposed to safety risks and may suffer severe injuries, poisoning or even loss of life.

- Make sure that no hot or hazardous fluid is in the equipment or the pipes.
- Make sure that the pipes upstream and downstream of the equipment are depressurised.
- Make sure that the installation is switched off and protected against unauthorised or unintended activation.
- Make sure that the equipment and the pipes have cooled down to room temperatures.
- Wear protective clothing that is suitable for the fluid and, if necessary, wear protective gear.

For more information on suitable protective clothing and safety gear refer to the safety data sheet of the fluid in question.



CAUTION

Danger of bruising if the equipment falls down.

- When removing the equipment make sure the it is safely held in place and cannot fall down.

Suitable measures are for instance:

- ▶ Equipment that is not too heavy may be supported by a second person.
- ▶ For heavy equipment use suitable lifting equipment of sufficient strength.
- Detach the end connections of the equipment from the pipes.
- Put the equipment onto a suitable base.
- Store the equipment as described in section "Storing the equipment" from page 11 onwards.

Re-using equipment after storage

Observe the following instructions if you want to remove the equipment and use it again somewhere else:

- ▶ Make sure that the equipment is free of any fluid residues.
- ▶ Make sure that all connections are in good condition and leak-free.
- Use the equipment only for its intended purpose and the service conditions for which it was specified.

Disposing of the equipment



Caution

Environmental damage may be caused by poisonous fluid residues.

- Before disposing of the equipment make sure that it is clean and free of fluid residues.
- For the disposal of all materials observe the pertinent legal regulations concerning waste disposal.

The equipment is made from the following materials:

Component part	EN number	ASTM
Body and cover TK 23	5.1301	A126B
Body and cover TK 24	1.0619	A216WCB
Bolts TK 23, TK 24 DN50	1.7709	—
Bolts TK 24 DN65– 100	1.7225	A193 B7
Gasket	Graphite/CrNi	
Membrane regulator capsule	Hastelloy®/Stainless steel	
Other internals	Stainless steel	



The equivalent ASME material specifications are stated for guidance only. Physical and chemical properties of the materials can therefore differ from the ASME specification for materials.

- For more details please contact the manufacturer.

Technical data

Dimensions and weights

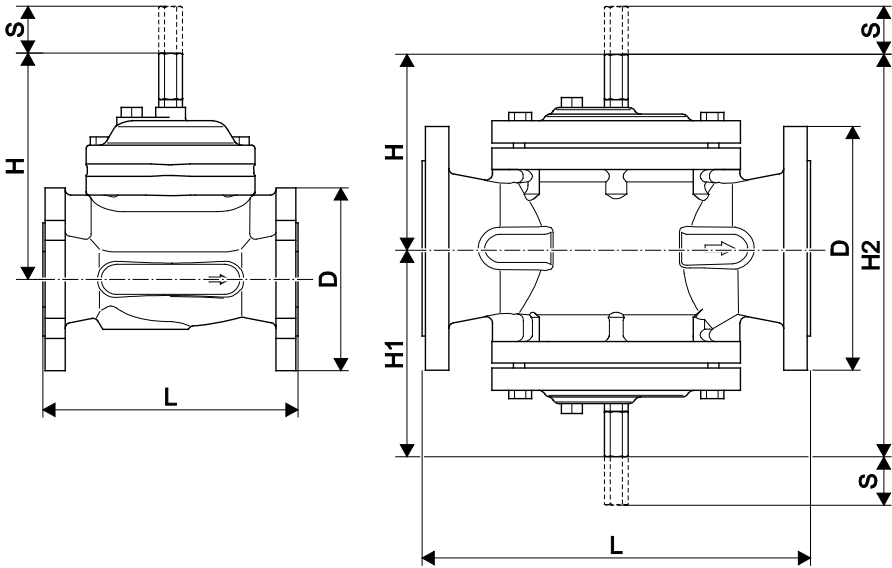

		TK 23				TK 24			
Nominal size	[mm]	50	65	80	100	50	65	80	100
	[inch]	2	2½	3	4	2	2½	3	4
Dimensions [mm]	L	230	290	310	350	230	290	310	350
	H	204	175	175	175	204	180	180	180
	H1	–	175	175	188	–	170	170	188
	H2	–	350	350	363	–	350	350	368
	D	165	185	200	220	165	185	200	235
	S ¹	approx. 50	approx. 200			approx. 50	approx. 200		
Weight	[kg]	16	25	27	43	17	28	31	56

1 Withdrawal distance

Pressure & temperature ratings

Limiting conditions for body	TK 23		TK 24	
	PMA (admissible service pressure) [barg]	16	9.6	25
TMA (admissible temperature) [°C]	120	300	120	400

Limiting conditions for regulator unit	TK 23		TK 24	
	Membrane regulator capsule OH2	Membrane regulator capsule 5H2	Membrane regulator capsule OH2	Membrane regulator capsule 5H2
PMO (admissible operating pressure) [barg]	13 ¹		21 ¹	
TMO (admissible inlet temperature)	t _s ²			
ΔPMX (admissible differential pressure)	< 5	1–10	< 5	1-14

- 1 If the membrane regulator capsule type OH2 is used the max. admissible service pressure is 5 barg.
- 2 Saturated steam temperature. Do not exceed max.admissible superheat condition of 5 K.

Capacity Charts

Capacity chart for hot water

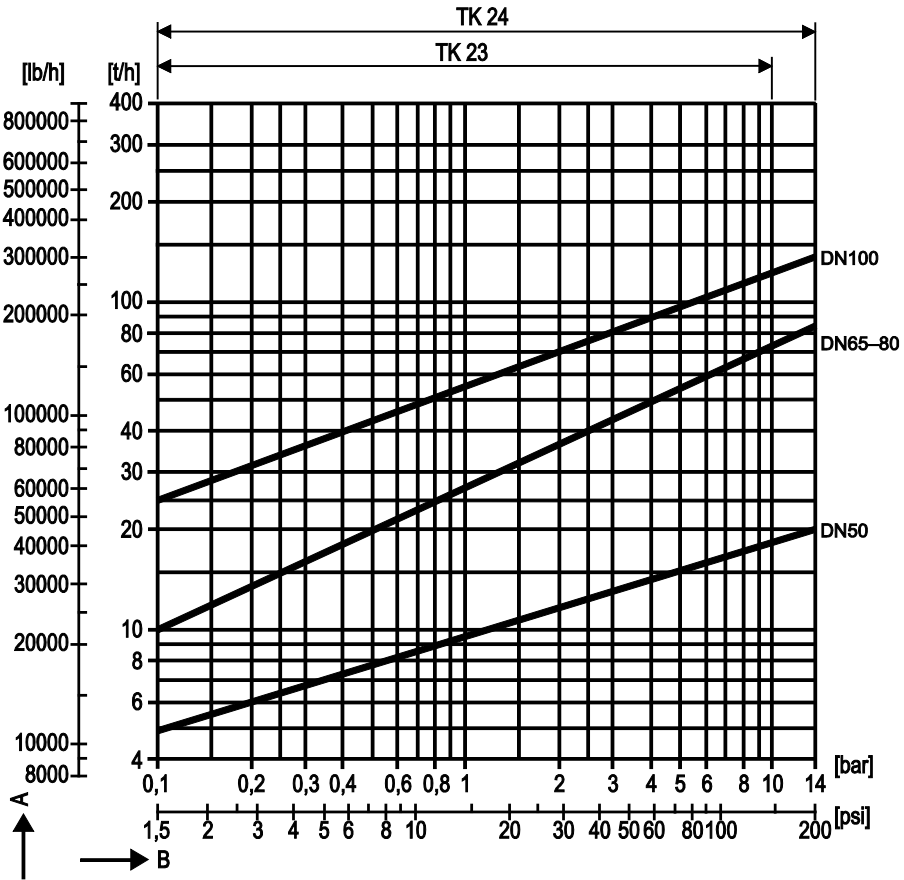

- A Flowrate
- B Differential pressure ΔPMX

Capacity chart for cold water

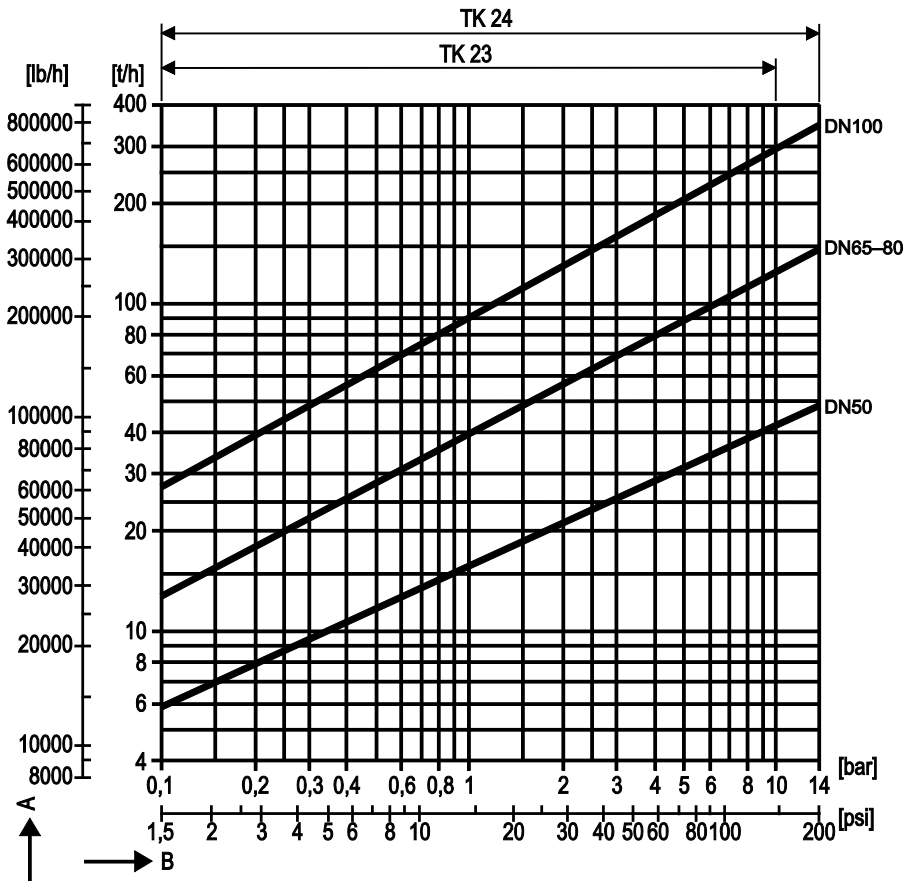

- A Flowrate
- B Differential pressure Δ PMX

Lift-Restriction Charts

Lift-restriction chart DN 50

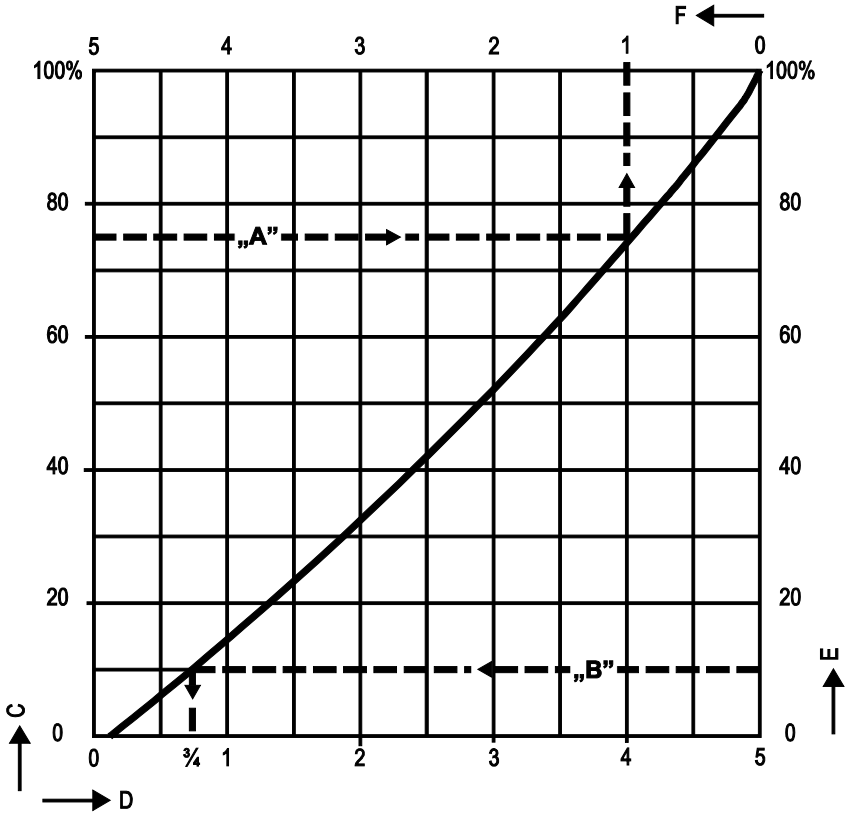

- A Example of maximum capacity
- B Example of minimum flowrate (leak passage)
- C Max. capacity in % of max. possible flowrate
- D Turns to the left
- E Min. capacity in % of max. possible flowrate
- F Turns to the right

Lift-restriction chart DN 65 - 80

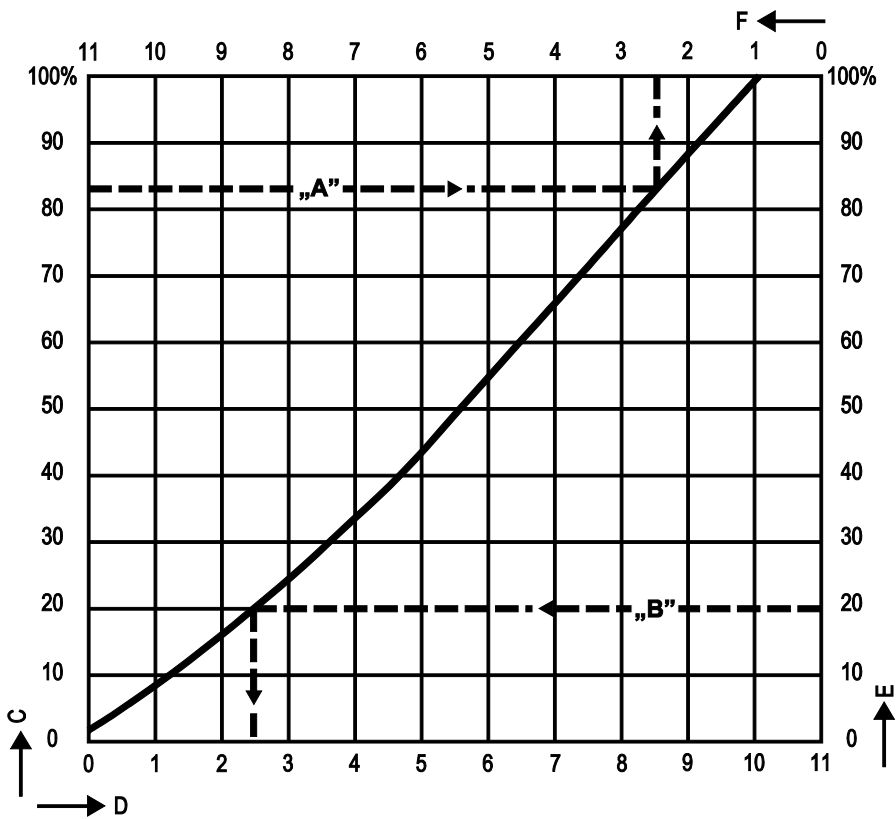

- A Example of maximum capacity
- B Example of minimum flowrate (leak passage)
- C Max. capacity in % of max. possible flowrate
- D Turns to the right for lower adjustment screw (minimum flowrate)
- E Min. capacity in % of max. possible flowrate
- F Turns to the right for upper adjustment screw (maximum flowrate)

Lift-restriction chart DN 100

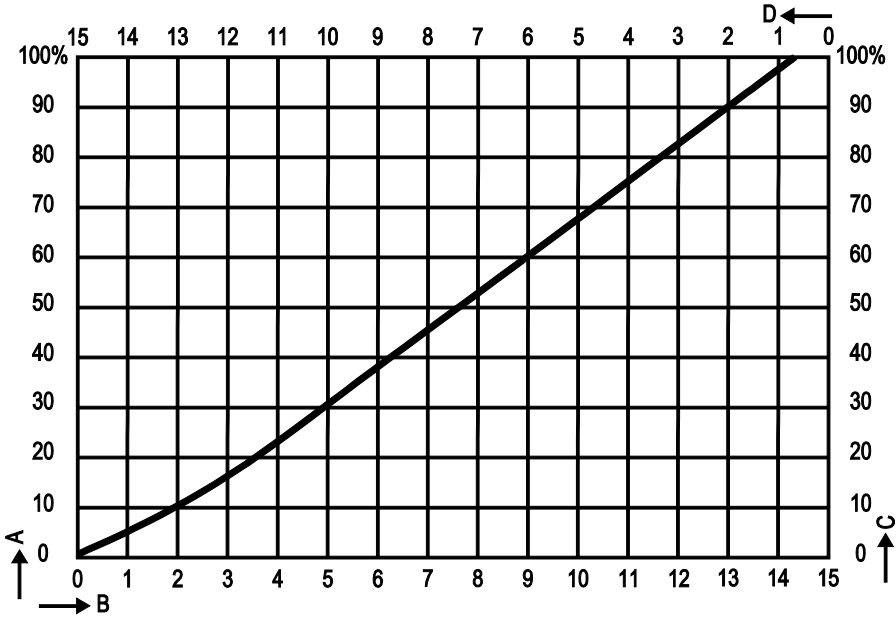

- A Max. capacity in % of max. possible flowrate
- B Turns for lower adjustment screw (minimum flowrate)
- C Min. capacity in % of max. possible flowrate
- D Turns for upper adjustment screw (maximum flowrate)

Manufacturer's declaration

For more information on the Conformity Assessment according to European rules refer to our Declaration of Conformity or our Declaration by Manufacturer.

To download the current Declaration of Conformity or Declaration by Manufacturer go to www.gestra.com/documents or contact:

GESTRA AG

Münchener Straße 77

28215 Bremen

Germany

Telefon +49 421 3503-0

Telefax +49 421 3503-393

E-Mail info@de.gestra.com

Web www.gestra.de

This declaration is no longer valid if modifications are made to the equipment without consultation with us.



Agencies all over the world: www.gestra.de

GESTRA AG

Münchener Straße 77
28215 Bremen
Germany

Telefon +49 421 3503-0
Telefax +49 421 3503-393
E-Mail info@de.gestra.com
Web www.gestra.de

819309-01/07-2017 kx_mm (803358-03) © GESTRA AG Bremen Printed in Germany